

INSTALLATION INSTRUCTIONS

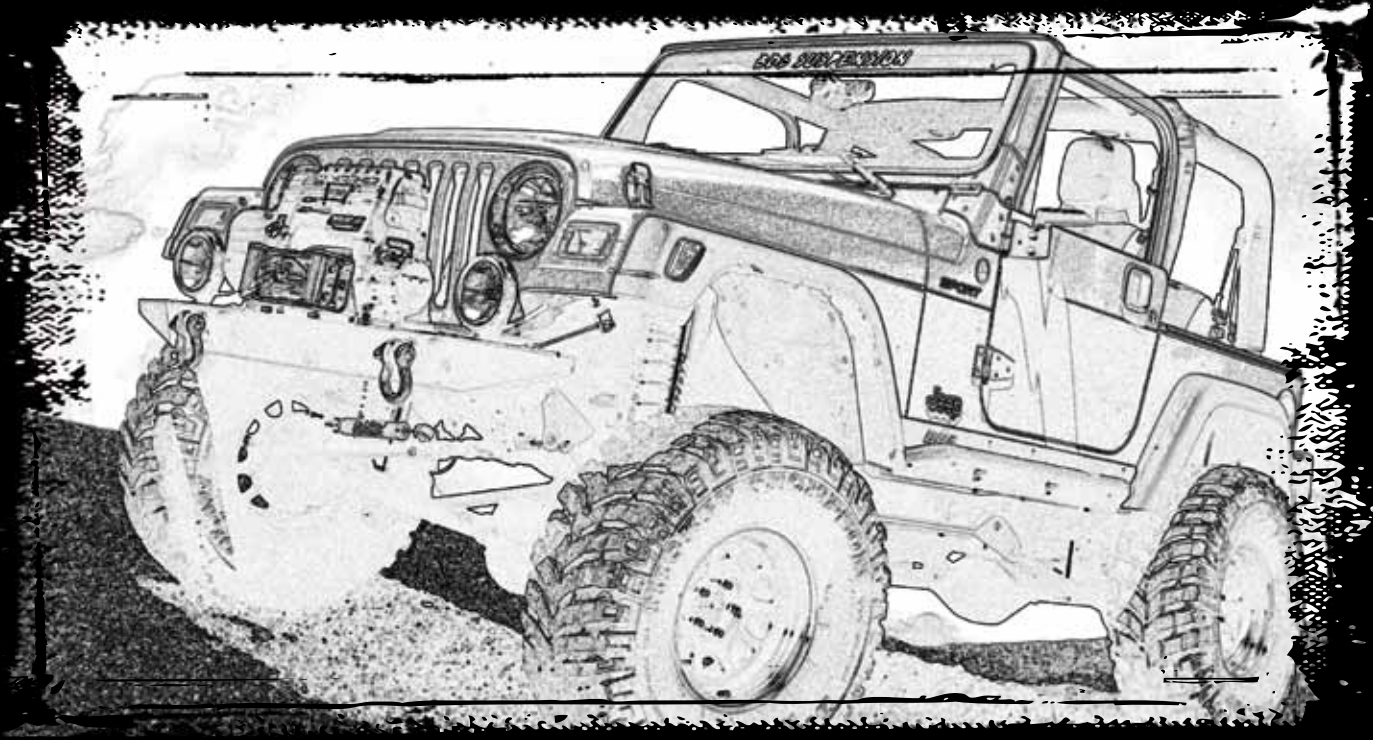

BDS PART # 014656

491 W. Garfield Ave., Coldwater, MI 49036 • Phone: 517-279-2135 • Web/live chat: www.bds-suspension.com • E-mail: tech@bds-suspension.com

HARDCORE LIMITED LIFETIME WARRANTY

6.5" Long Arm Suspension System

Jeep Wrangler TJ | 1997-2006

Rev. 080614



Read And Understand All Instructions And Warnings Prior To Installation Of System And Operation Of Vehicle.

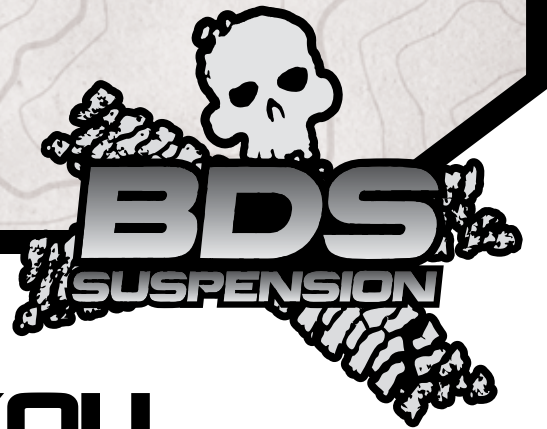

THANK YOU

Your truck is about to be fitted with the best suspension system on the market today. That means you will be driving the baddest looking truck in the neighborhood, and you'll have the warranty to ensure that it stays that way for years to come. Thank you for choosing BDS Suspension!



**FOLLOW US FOR UP-TO-DATE
EVENT COVERAGE AND MORE**



Visit 560plus.com for more information.

TRACTION CONTROL



In an effort to reduce the risk of rollover crashes the National Highway Traffic Safety Administration (NHTSA) established the Federal Motor Vehicle Safety Standard (FMVSS)

No. 126 requiring all new passenger vehicles under 10,000 lbs GVWR include an electronic stability control (ESC) system as standard equipment. Effective August 2012 this law requires aftermarket products to be compliant with these same standards.

NOT APPLICABLE TO ALL BDS SUSPENSION SYSTEMS

FOR YOUR SAFETY

Certain BDS Suspension products are intended to improve off-road performance. For your safety and the safety of your passengers, take the following precautions.

- **HANDLING** - Modified vehicles will likely handle differently than a factory equipped vehicle.
- **ROLLOVERS** - Extreme care must be used to prevent loss of control or vehicle rollover.
- **DRIVE SAFELY** - If you do fail to drive your modified vehicle safely, it may result in serious injury or death.
- **DON'T MIX SYSTEMS** - We do not recommend the combined use of suspension lifts, body lifts, or other lifting devices.
- **STAY SOBER** - You should never operate your modified vehicle under the influence of alcohol or drugs.
- **OBEY THE LAW** - Always drive your modified vehicle at reduced speeds to ensure your ability to control your vehicle under all driving conditions. Always wear your seat belt.

RECOMMENDATIONS

- **PROFESSIONAL INSTALLATION** - BDS Suspension recommends that this system be installed by a professional technician.
- **PROFESSIONAL KNOWLEDGE** - Disassembly/reassembly procedures and post installation checks must be known to install this system.
- **SPECIAL LITERATURE REQUIRED** - OE Service Manual for model/year of vehicle. Refer to manual for proper disassembly/reassembly procedures of OE and related components.
- **OE RECOMMENDATIONS** - Adhere to recommendations when replacement fasteners, retainers and keepers are called out in the OE manual.
- **LARGER RIM AND TIRE COMBINATIONS** - These may increase leverage on suspension, steering, and related components. When selecting combinations larger than OE, consider the additional stress you could be inducing on the OE and related components.
- **DRIVE LINE VIBRATION** - After installation vehicles may experience drive line vibrations. Angles may require tuning, slider on shaft may require replacement, shafts may need to be lengthened or trued, and U-joints may need to be replaced.
- **SHOP SAFETY** - Secure and properly block vehicle prior to installation of components. Always wear safety glasses when using power tools.
- **WITH A HOIST** - If installation is to be performed without a hoist, we recommend rear alterations first.
- **AMOUNT OF LIFT** - Due to payload options and initial ride height variances, the amount of lift is a base figure. Final ride height dimensions may vary in accordance to original vehicle attitude. Always measure the attitude prior to beginning installation.

AFTER THE INSTALLATION, BEFORE YOU DRIVE

- Check all fasteners for proper torque.
- Check to ensure for adequate clearance between all rotating, mobile, fixed, and heated members.
- Verify clearance between exhaust and brake lines, fuel lines, fuel tank, floor boards and wiring harness.
- Check steering gear for clearance. Test and inspect brake system.
- Perform steering sweep to ensure front brake hoses have adequate slack and do not contact any rotating, mobile or heated members.
- Inspect rear brake hoses at full extension for adequate slack.
- Failure to perform hose check/ replacement may result in component failure.
- Longer replacement hoses, if needed can be purchased from a local parts supplier.
- Perform head light check and adjustment.
- Re-torque all fasteners after 500 miles. Always inspect fasteners and components during routine servicing.

CONTENTS OF YOUR KIT



014651

Part #	Qty	Description
01387B	1	Upper Control Arm Mount - Pass
01388B	1	Upper Control Arm Mount - Drv
01323B	1	Support Tube
01363B	1	Track Bar Bracket Support
02590	1	Long Arm Bracket - Drv
02591	1	Long Arm Brkt - Pass
A221	2	Front Upper Control Arm Assembly
A148B	1	Front Adjustable Track Bar
A222	2	Rear Upper Control Arm Assembly
15211	6	1/2"-13 x 2 Bolt
01352	2	Misalignment Bushing
YJTC6	6	Tapered Washer
W76USS	6	7/16" USS Washer
766	1	Bolt Pack-Front Track Bar Support
	1	1/2"-13 x 1-1/2" bolt grade 8 yellow zinc
	1	1/2"-13 x 5" bolt grade 8 yellow zinc
	2	1/2"-13 prevailing torque nut yellow zinc
	3	1/2" SAE flat washer thru-hardened yellow zinc
	1	7/16" USS flat washer thru-hardened yellow zinc
732	1	Bolt Pack - Main Control Arm Mounts
	4	12mm-1.75 x 50 mm bolt
	4	7/16" USS flat washer
	2	12mm-1.75 x 30mm button head bolt

014651 (cont.)

787	1	Bolt Pack - Control Arms
	4	9/16"-12 x 4" bolt
	4	9/16"-12 prevailing torque nut
	8	9/16" SAE flat washer thru-hardened
	4	7/16"-14 x 3-1/2" bolt
	4	7/16"-14 prevailing torque nut
	8	7/16" SAE flat washer
	2	3/8"-16 x 1-1/4" self-tapping bolt
	2	5/16" USS flat washer
	4	12mm-1.75 x 80mm bolt
	4	12mm-1.75 prevailing torque nut
	8	12mm flat washer
731	1	Bolt Pack - Upper Control Arm Brackets
	2	10mm-1.50 x 30mm bolt
	6	3/8" USS flat washer
	4	3/8"-16 x 3-1/2" bolt
	4	3/8"-16 prevailing torque nut
	8	3/8" SAE flat washer
	2	3/8"-16 x 1" hex flange head self-tapping bolt
	2	7/16"-14 x 3" bolt
	4	7/16" SAE flat washer
	2	7/16"-14 prevailing torque nut
	2	10mm-1.50 x 90mm bolt
	2	10mm-1.50 prevailing torque nut

Coil Springs		
Part #	Qty	Description
BDS034651	1	Front Coil Springs
BDS034659	1	Rear Coil Springs

014660		
Part #	Qty	Description
A220	4	Front & Rear Lower Control Arm
60107	4	90 degree grease fitting

014656		
Part #	Qty	Description
084404R	1	Dropped Pitman Arm
911103	2	Sway Bar End Link
01332B	1	Track Bar Bracket
3396	4	Bump Stop Extension
3529BK	4	Bump Stop
01359B	1	Track Bar Bracket
01346	1	E-brake Relocation
22510	2	Front Brake Line
5188	3	Brake Line Clip
B06103C	3	Brake Line L-Bracket
CCW-03-050	4	Brake Line Crush Washer
099000	3	Nylon Cable Tie
22511	1	Rear Brake Line
342701	2	Loctite
SB58BK	4	5/8" ID Hourglass Bushing
45313	4	.625 x .109 x 1.375 Sleeve
54587	1	.750 x .090 x 1.575 Sleeve
01461	1	Rear Shock Relocation Bracket
125	1	5/8" x 12mm ID x 1.22" Sleeve
01356	1	Nut Tab
01360	2	Weld on Sway Bar Link Mount
01361	2	Weld on Sway Bar Link Mount
01565	1	Weld on Stabilizer Mount
M02888BK	2	Track Bar Bushing
133	1	.625 x .058 x 1.375 Sleeve
01379	2	Spring Retainer
709	1	Bolt Pack - Sway Bar Links
	4	10mm-1.50 x 60mm bolt grade 10.9 clear zinc
	4	10mm-1.50 prevailing torque nut clear zinc
	8	3/8" USS flat washer clear zinc
	2	7/16"-14 prevailing torque nut
712	1	Bolt Pack - Shock Brackets
	2	12mm-1.75 x 65mm bolt
	2	12mm-1.75 prevailing torque nut
	4	1/2" SAE flat washer
	2	3/8"-16 x 1" bolt grade 8 bolt
	2	3/8"-16 prevailing torque nut
	4	3/8" SAE flat washer

014656 (cont.)		
752	1	Bolt Pack - Rear Track Bar Bracket
	2	12mm-1.75 x 75mm bolt
	1	12mm-1.75 prevailing torque nut
	3	1/2" SAE flat washer
	1	3/8"-16 x 1" bolt
	1	3/8"-16 prevailing torque nut
	2	3/8" SAE flat washer
	1	3/8"-16 x 3/4" self-tapping bolt
	1	5/16" x 3/4" self-tapping bolt
	2	7/16"-14 x 1" bolt
	2	7/16"-14 prevailing torque nut
	4	7/16" SAE flat washer
753	1	Bolt Pack - Front Track Bar Bracket
	1	9/16"-12 x 2" bolt
	1	9/16"-12 prevailing torque nut
	1	9/16" SAE flat washer
	1	7/16"-14 x 1-1/4" bolt
	1	7/16" SAE flat washer
	1	1/2"-13 x 2-1/2" button head bolt
	3	1/2"-13 prevailing torque nut
	5	1/2" SAE flat washer
	1	1/2"-13 x 3" bolt
	1	1/2"-13 x 2-1/2" bolt
754	1	Bolt Pack - Bump Stops/ E-brake Cable
	4	3/8"-16 x 4" self-tapping bolt
	4	3/8" USS flat washer
	2	5/16"-18 x 1" bolt
	2	5/16"-18 prevailing torque nut
	4	5/16" SAE flat washer
	2	5/16"-18 x 1" self-tapping bolt
	1	1/8" x 1-1/4" cotter pin

124652		
Part #	Qty	Description
A100	1	Sway Bar Link Assembly
01325	2	Sway Bar Link U-Bracket
01316	2	13.5in Lanyard
01302	2	Disconnect Stud
45313	2	.625 x .109 x 1.375 Sleeve
718	1	Bolt Pack - Sway Bar Disconnects
	2	1/2-20 prevailing torque nut
	4	1/2" SAE flat washer
	2	3/8"-16 x 2-1/2" bolt
	2	3/8"-16 prevailing torque nut
	4	3/8" SAE flat washer
	2	7/16"-14 x 1-1/2" bolt
	2	7/16"-14 prevailing torque nut
	2	7/16" SAE flat washer
	2	7/16" USS flat washer
	2	#10-16 x 5/8" self-drilling screw

TIRES AND WHEELS

6.5" Lift:

35 x 12.50 on 15x8 or 16x8 with 3.5" backspacing

SPECIAL TOOLS

Reciprocating saw
Cutoff wheel and grinding disc
Pitman arm puller
Welder

TECH TIPS

TROUBLESHOOTING INFORMATION FOR YOUR VEHICLE

1. A slip yoke eliminator kit and CV style rear drive shaft is required.
2. May require exhaust modification.
3. Some welding required.
4. Long arm systems not designed for long wheel base unlimited models.

INSTALLATION INSTRUCTIONS

PRE-INSTALLATION NOTES

1. These installation instructions are written for an install to be performed on the ground using hydraulic jacks and jack stands. While this is not the preferred/easiest method it is the most common. Ideally this installation should be performed using an appropriate two-post hoist. Using a hoist will allow for the installation to be performed more quickly and easily.
2. This system includes new braided stainless steel brake lines. Installation of these lines requires the entire brake system to be bled following the completed installation and prior to operating the vehicle. Consult your owner's manual for the proper brake fluid to use for your vehicle. Fluid is not included in this kit.
3. This installation requires welding. This should be performed by a certified welder.
4. This system requires the installation of a slip-yoke eliminator kit and CV style rear drive shaft.

FRONT INSTALLATION

1. Park the vehicle on a clean, flat surface and block the rear wheels for safety.
2. Disconnect the positive and negative battery cables from the battery.
3. Raise the front of the vehicle and support the frame rails with jack stands just behind the front bumper.
4. Disconnect the rear drive shaft from the axle and transfer case.
5. Remove the 4 transmission mount nuts.
6. Support the transmission/transfer case with a transmission jack. Remove the 6 skid plate bolts and the skid plate from the vehicle.
7. The skid plate must be modified to provide clearance for the new lower control arm mounts. Place the frame mounting surface of the skid plate down.

8. **97-02 Models:**

Part 1: This trimming procedure is to be done on the rear driver's side corner of the skid plate only. (Figure 1)

- A. Measure in toward the center of the skid plate 2" from the center of the rearmost hole and make a cut line perpendicular to the back edge.
- B. Measure forward 3" from the center of the rearmost hole and make a cut line perpendicular to the outside edge. Measure in from the outside edge of the skid plate 5/8" and mark. Make a cut line from the 3" mark parallel to the outer edge at the 5/8" mark all the way to the rear edge (Fig 1).
- C. Measure back from the center of the rear hole 1-3/4" and make a cut line perpendicular with the outside edge.
- D. Make the "L" shaped cut from the rear corner of the skid plate with a reciprocating saw, cut-off wheel and/or plasma cutter. Remove all sharp edges/corners with a grinder and paint all bare metal to prevent corrosion.

FIGURE 1

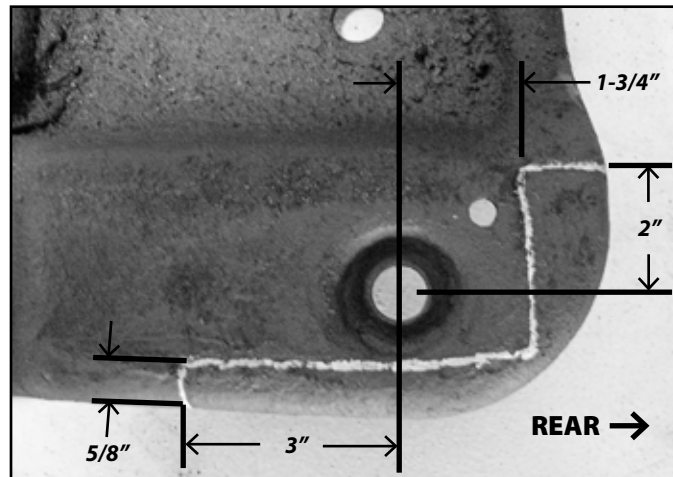

Part 2: This trimming procedure is to be done on the rear passenger's side corner of the skid plate. (Figure 2)

- A. Make a cut line that is in line with the forward edge of the rearmost hole and perpendicular with the outside edge.
- B. Measure in 5/8" from the outside edge of the skid plate and make a cut line parallel with the outside edge from the rear all the way to the cut line made in step A.
- C. Make the cut from the rear corner of the skid plate with a reciprocating saw, cut-off wheel and/or plasma cutter. Remove all sharp edges/corners with a grinder and paint all bare metal to prevent corrosion.

FIGURE 2

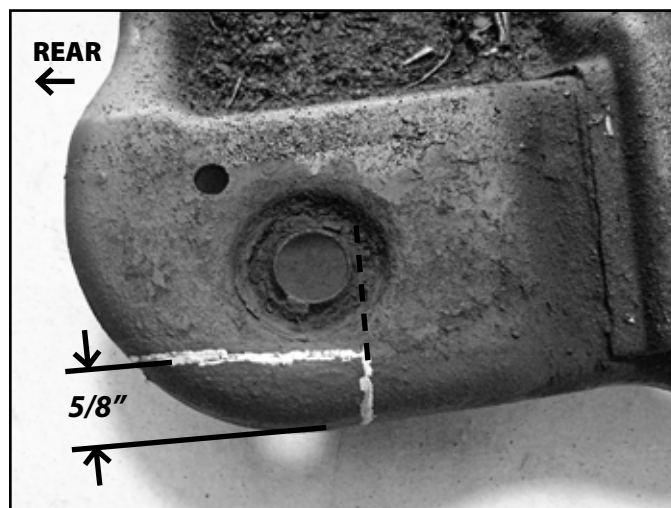

Part 3: Driveshaft Clearance for lifts over 4.5"

- A. Locate the front set of four slotted holes in the bottom of the skid plate. Measure from the center of the front driver's side slot, toward the driver's side 6" and mark. Place the provided cut template so that the corner is located at the 6" mark and the longer edge is flush with the front edge of the skid plate. Using the template as a guide, make a cut line from the driveshaft clearance cut. Make the trapezoid shaped cut from the skid plate with a reciprocating saw, cut-off wheel and/or plasma cutter (Fig 3). Remove all sharp edges/corners with a grinder and paint all bare metal to prevent corrosion. (See template on last page.)

FIGURE 3



9. **03-06 Models:** This trimming procedure is to be done on the rear driver's and passenger's side corners of the skid plate.
- A. Measure in toward the center of the skid plate 2" from the center of the rear most hole and make a cut line that runs perpendicular to the back edge.
- B. Measure forward from the rear most hole 1-1/2" and make a mark perpendicular to the outside ends of the skid pan until it intersects the mark made in step A.
- C. Measure forward from the center of the rearmost hole 6-1/4" and make a cut line perpendicular to the outside edge. Measure in from the outer edge of the skid plate 5/8" and mark. Make a cut line from the 6-1/4" mark, parallel to the outer edge at the 5/8" mark until it hits the exiting cut line made in step B (Fig 4).

FIGURE 4

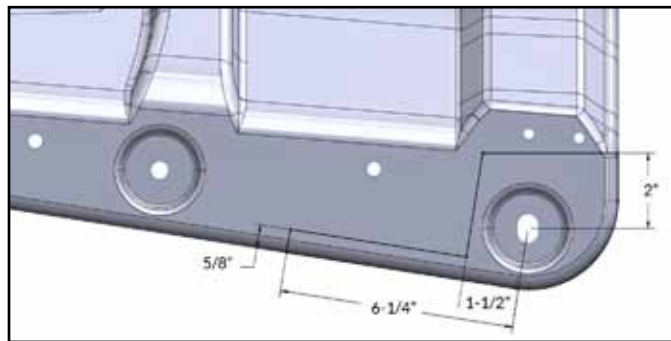

- D. Make the "L" shaped cut from each of the rear corners of the skid plate with a reciprocating saw, cut-off wheel and/or plasma cutter. Remove all sharp edges/corners with a grinder and paint all bare metal to prevent corrosion.
10. Mount the new provided lower control arm subframes (02590-driv, 02591-pass) to the vehicle using the provided hardware (Fig 5). For 97-02 models use 1/2" x 2" bolts. For 03-06 models use 12mm x 50mm bolts (BP 732). Attach the subframes to the frame rails using the mounting holes that are correct for the model year of vehicle – see figure 5. Snug the hardware so that the subframes are mounted tight to the frame.

FIGURE 5

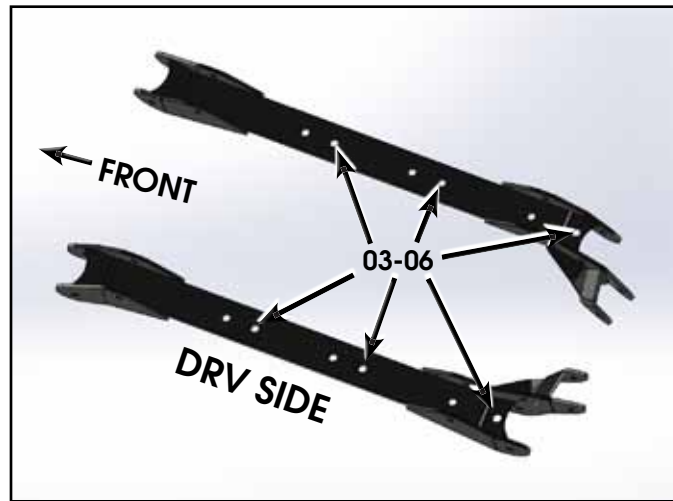

11. With the subframes properly mounted in position, using the holes in the subframes as a guide, mark the horizontal mounting holes (Fig 6) to be drilled in the frame (4 holes total).

FIGURE 6



12. Remove the subframes and drill 7/16" holes at the marks on the frame. Take care to drill the holes straight (square) to the frame. Drill through both the outer and inner surfaces of the frame. Caution: Check for lines and hoses on the inner frame rail before drilling.
13. When all four horizontal subframe mounting holes are drilled, reinstall the subframes on the frame rails with the provided 7/16" x 3-1/2" bolts, nuts and 7/16" SAE washers (BP 787) through the drilled holes. Leave hardware loose at this time.
14. Install the modified skid plate in the vehicle (Fig 7). Use Loctite on all mounting bolts.
15. **97-02 models:** Attach the skid plate to the frame using six 1/2" x 2" bolts with the provided 7/16" USS washers followed by the tapered washers (YJTC6). When all the bolts are installed, torque the 1/2" hardware to 65 ft-lbs.
16. **03-06 models:** Attach the skid plate to the frame using four 12mm x 50mm bolts and 7/16" USS washers (BP 732). Install a provided 12mm x 30mm button head bolt in the rearmost hole of each subframe. With all the bolts installed, torque the six 12mm bolts to 65 ft-lbs.

FIGURE 7

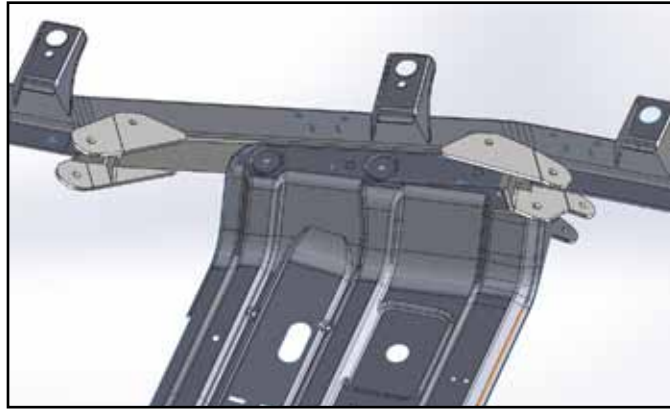

17. With the skid plate completely installed, go back and torque the four 7/16" horizontal subframe bolts to 40 ft-lbs. Do not over-torque the 7/16" bolts.
18. Lower the transmission/transfer case back on the skid plate by aligning the four transmission mount studs in the skid plate mounting holes. Fasten the mount with the original nuts and torque to 20 ft-lbs.
19. Support the front axle with a hydraulic jack.
20. Remove the wheels.
21. Remove the lower control arms from the axle and the frame. Retain hardware and discard control arms.
22. The front lower control arm pockets must be removed from the frame to provided clearance for the new long lower control arms (Fig 8). Cut the pockets completely off of the frame using a cut-off wheel and/or reciprocating saw. Take special care not to cut into the frame. Grind that area smooth with a medium grit grinding wheel and paint all bare metal to prevent corrosion. The mounts must be removed completely.

FIGURE 8

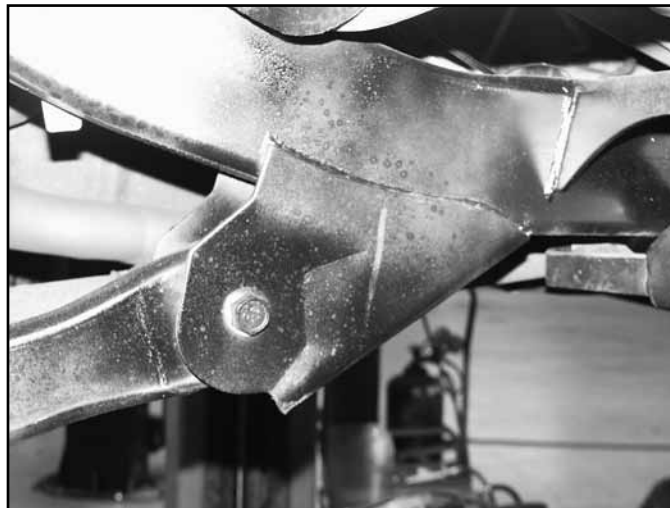

23. Disconnect the rubber brake line from metal hard line.
24. Disconnect brake line from caliper and discard hardware. Ensure old washer is removed from caliper and brake line mounting area.
25. Install new upper brakeline bracket (B06103C) with OE bolt. Leave loose.
26. Mount hard line into new bracket before installing new stainless steel line.
27. Install BDS front brake line (22510) by attaching upper portion first. Tighten fitting securely. Fasten the brake line to the bracket with a new clip (5188). Torque bracket mounting bolt to 20 ft-lbs.
28. Install lower portion with provided new crush washers. Note: One washer is required on EACH side of the fitting. Brake line must face up after installation. Torque OE banjo bolt to 25 ft-lbs.
29. Disconnect the sway bar end links from the axle and sway bar (Fig 9). The link is fit into the sway bar with a taper that must be released. Use a pickle fork to remove the link from the sway bar. On some models the end link bolt has a serrated shank that is pressed into the mount. The bolt will need to be pressed out.

FIGURE 9

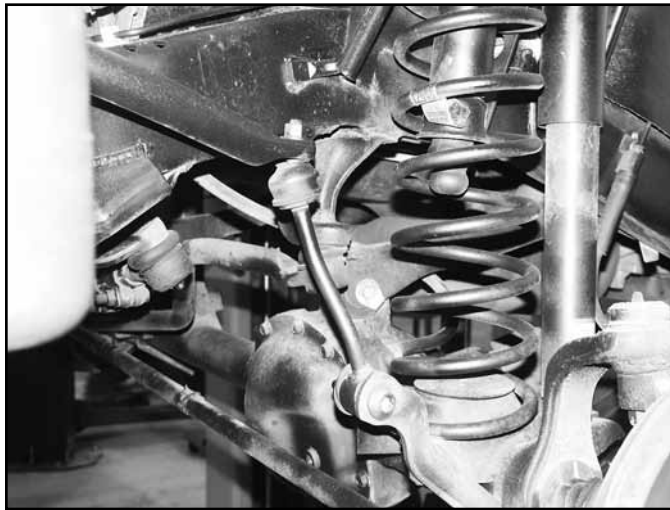

30. Remove OE steering stabilizer from the axle and drag link (Fig 10). Remove the tapered stud from the drag link with a pickle fork or by striking the drag link near the stud with a hammer to free the taper. Discard the stabilizer and hardware.

FIGURE 10

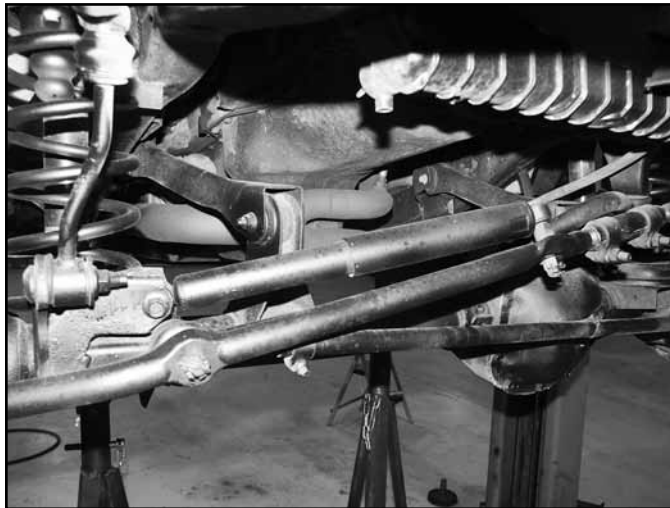

31. Disconnect the steering drag link from the pitman arm (Fig 11). Remove the cotter pin and nut. Use a pickle fork to dislodge the drag link from the pitman arm. Retain castellated mounting nut.
32. Remove the nut and washer mounting the pitman arm to the steering box (Fig 11). Remove the pitman arm from the steering box using an appropriate pitman arm puller. Note the indexing of the pitman arm before removal. Retain mounting nut and washer.

FIGURE 11



33. Install the new provided pitman arm (084404R) on the steering box in the same orientation as the OE was taken off. Fasten with the OE nut and washer. Torque nut to 185 ft-lbs.
34. Disconnect the front shocks from the axle. Retain the lower shock mounting hardware. Leave the shocks attached to the frame at this time as they will be used to help support the axle while installing the new control arms.
35. If equipped, remove the coil spring retaining clips at the axle.
36. Lower the axle and remove the coil springs from the vehicle.
37. Remove the front axle bump stops from the frame (Fig 12).

FIGURE 12

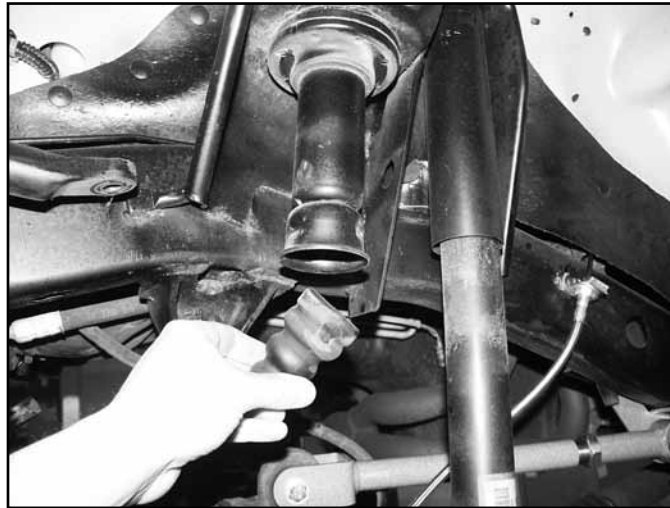

38. Reattach the shocks to the axle with the OE hardware. These will aid in supporting the axle while the new lower arms are installed.
39. Locate (2) pre assembled long lower control arms (A 220). Adjust the length to 29-1/4". Install a provided 90° grease zerk (60107) in the flex end so it faces 45° from facing down the arm and towards the outside of the vehicle. The arms are installed with the flex eye at the frame with the bend towards the inside of the vehicle.
Note: The lower arms are the same front and rear.
40. Install the new lower control arms in the OE axle bracket with the original hardware and the new subframe pocket with a 9/16" x 4" bolt, nut and 9/16" SAE washers (BP 787). The 90° fitting should be pointing at a 45° angle towards the outside. Leave hardware loose (Fig 13).



Tip

With the shocks and front track bar still attached, just push the axle forward enough to attach the arms to the subframe.

FIGURE 13

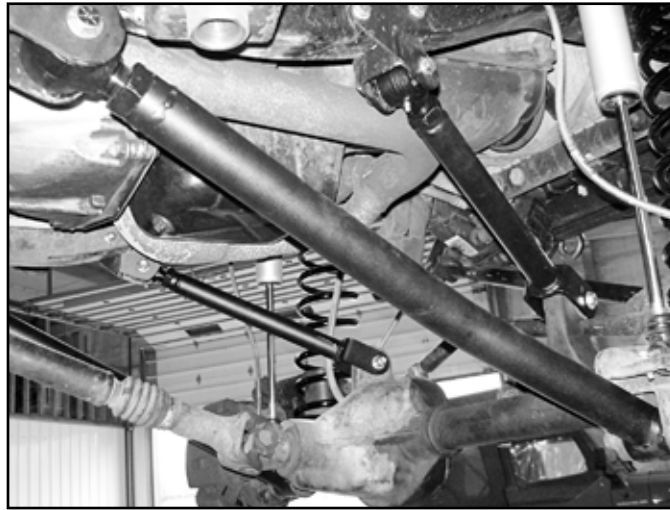

41. Remove the upper control arms from the front axle and frame. Retain the nut tab from the frame mount.



Tip *Be sure that the axle is well supported.*

42. Complete the upper control arm bracket install one side at a time. Loosely install the provided upper control arm drop bracket (01387-pass, 01388-drv) to the OE upper control arm pocket with a 10mm x 35mm bolt, 3/8" USS washer (BP 731) and the OE nut tab. The bracket will run from the outer portion of the OE pocket down to the frame and wrap around to the outside surface of the frame (Fig 14A, B). Adjust the bracket so that it is flush to the bottom and outside surfaces of the frame. Using the bracket as a template, mark the 3 mounting holes to be drilled. Allow the bracket to swing down out of the way.

FIGURE 14A

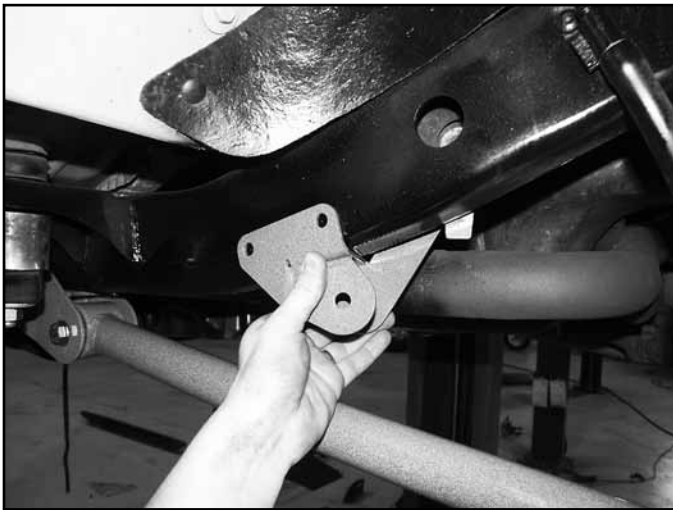

FIGURE 14B



43. Drill 3/8" holes at the two marks on the outside surface of the frame. Drill the holes all the way through the frame.
Note: Try to drill as straight as possible (perpendicular to the outside of the frame).
44. Drill a 5/16" hole at the mark on the bottom of the frame, only drilling through the bottom portion (not all the way through).
Note: It may be necessary to disconnect the lower control arms one side at a time to gain drill clearance for the bottom hole.
45. Reposition the bracket to the frame and fasten through the outside 2 holes with 3/8" x 3-1/2" bolts, nuts and 3/8" SAE washers (BP 731). Leave loose.
46. Fasten the bracket to the bottom of the frame with a 3/8" x 1-1/4" self-tapping bolt (BP 731). Apply Loctite to the threads of the self-tapping bolt and torque all mounting hardware to 30 ft-lbs. Torque the 10mm bolt at the OE pocket last. The bracket will reform itself slightly to match the angle of the upper OE bracket.
47. Repeat the upper bracket installation of the opposite side of the vehicle. When positioning the bracket, make a reference dimension from the completed side to aid in locating the hole positions to ensure the brackets are located consistently from side to side.

48. Locate the new front upper control arm assemblies. Install a 10mm x 90mm bolt (BP 731) in the clevis end of each upper control arm. Measure from the center of the clevis (using the bolt to indicate center location) to the center of the eye of the control arm end (Fig 15). Adjust this distance to 17-3/4" (this is a starting point based on 6" of lift). Leave the jam nut loose.

Note: When installed in the vehicle, the grease fitting must be towards the ground. When adjusting the length of the arms, make them mirror images of one another, a driver's side arm and a passenger's side arm (Fig 10).

FIGURE 15

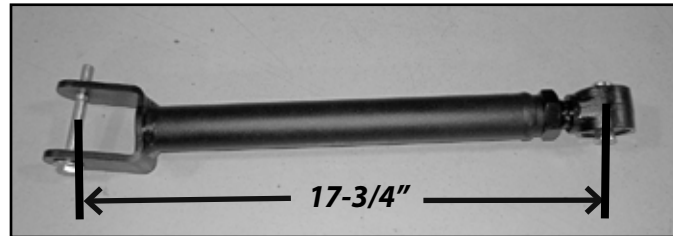

49. Install the new upper control arms in the new upper control arm brackets with 7/16" x 3" bolt, nut and 7/16" SAE washers (BP 731). Attach the arm to the OE front axle mount with the 10mm x 90mm bolt used earlier along with a 10mm nut and 3/8" USS washers (BP 731). Leave control arm hardware loose.
50. Disconnect the track bar from the axle and the frame (Fig 16A, B). Disconnect the track bar from the frame by remove the cotter pin and nut. Strike the track bar mount near the track bar end with a hammer to release the tapered end from the frame mount. Remove and discard the track bar and hardware.

FIGURE 16A

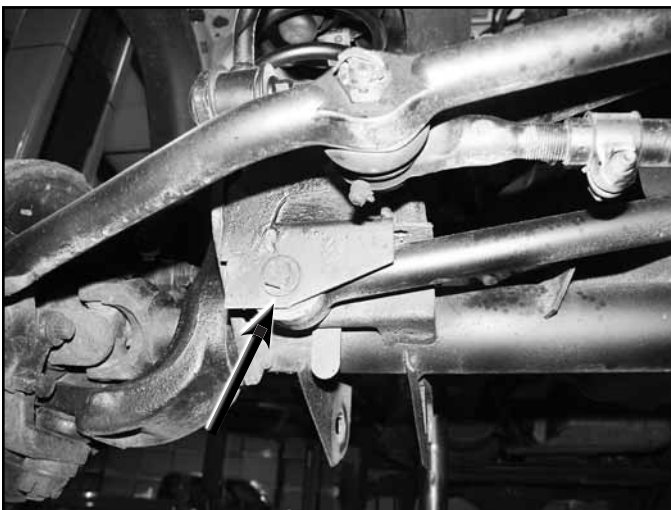
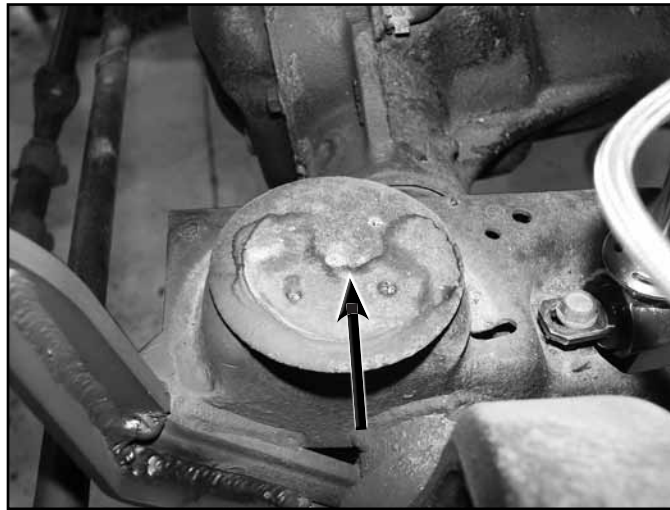

FIGURE 16B



51. Disconnect the shocks from the axle and the frame. Retain the lower hardware and discard the upper hardware and shock.
52. Grease and install the provided extended bump stops (3529) into the OE bump stop cups in the frame.
53. Locate the center of the coil mount on the axle and drill a 5/16" hole (Fig 17). Using one of the provided 3/8" self-tapping bolts, tap the hole and remove the bolt. A lower bump stop extension will be installed here after the coil spring is installed.

FIGURE 17



54. The front sway bar link axle mounts must be cut off to make room for the extended mounts provided. These new mounts will provide proper steering linkage clearance once the vehicle is lifted. Starting on the driver's side, make a cut mark on the axle link mount that is flush with the top surface of the axle coil mount. This mark will be approximately 2-5/8" from the top point of the link mount (Fig 18A, 18B).

FIGURE 18A



FIGURE 18B



55. Cut the link mount along the cut line with a reciprocating saw or cut off wheel. Take care to make the cut as straight and square as possible. The top portion that is cut from the driver's side mount will be used as a template for the passenger's side. Also, making a square cut here will help with setting up the welding process later on.
56. With the driver's side link mount removed, use the cut portion as a template by aligning the hole and the profile of the cut piece with the passenger's side mount. Mark the cut line on the passenger's mount (Fig 19). Note: A 1/2" bolt can be inserted in the mounting holes of the ends to aid in aligning them.

FIGURE 19



57. Cut the passenger's side link on the cut line in the same fashion as the driver's side.
58. With the link mounts cut, go through and remove any corrosion, oil, etc from the remaining portion of the OE link mounts as well as on the top of the OE stabilizer mounting bracket (pass. side). The surfaces must be corrosion/oil free to promote quality welds.

! Caution *A certified welder should perform all welding operations. This step can be skipped until the vehicle is complete and can be driven to a local welding shop if need be. Always keep a fire extinguisher near by when welding. Disconnect both the positive and negative battery cables before welding.*

59. Position a provided new link mount (01360) on the cut surface of the original driver's side mount. The front edge of the new mount should be flush with the front cut edge of the old mount. The inside surface of the link mount should also be flush/parallel with the inside surface of the original mount. Tack weld the new link mount in place (Fig 20A, B). Double check to see that the new mount is square with the original. Note: It is recommended to grind a bevel in the edge of the new link mount (outside where it meets the original mount) to promote good weld penetration of both pieces of material.

FIGURE 20A

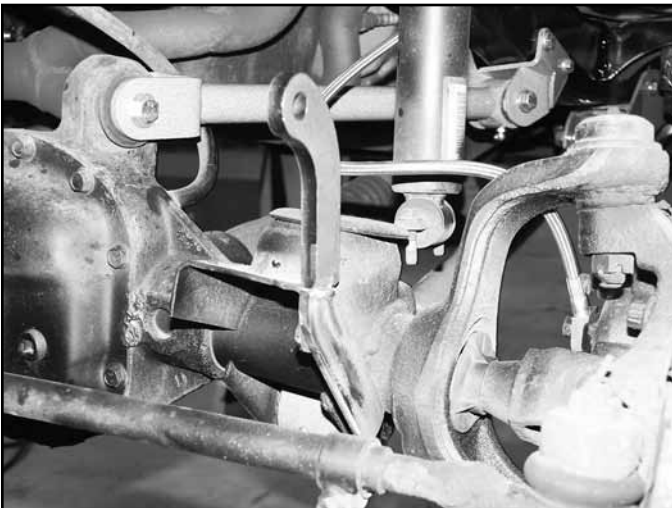
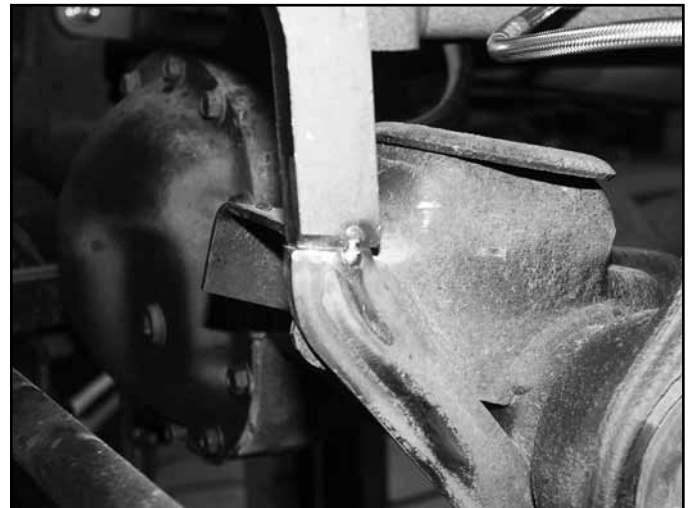
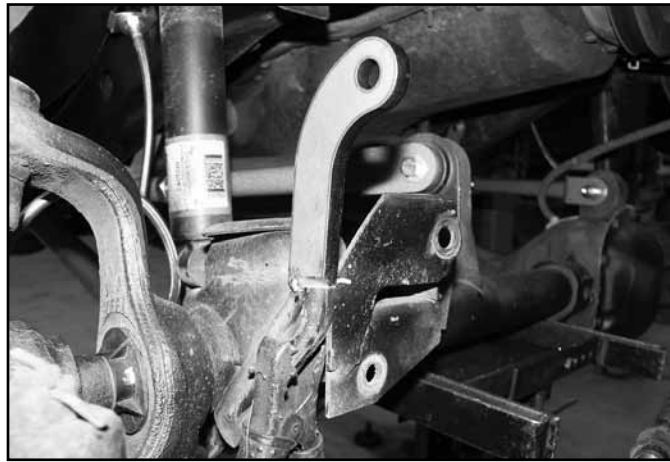

FIGURE 20B



60. Repeat the link setup procedure on the passenger's side of the vehicle (Fig 21). With both pieces tacked in place check the relationship between the two mounts to see that they are the same. Measure the inside distance between the tops of the links and the bottoms of the links to see that they are the same (approximately 38-1/2").

FIGURE 21



61. With the links positioned correctly, locate the provided formed side gussets (01361). Position the gussets so that they are parallel to the front surface of the original link mount and flush to the outside surface of the new link mount (Fig 22). Once they are in the desired position, tack weld the gussets in place.

FIGURE 22



62. With the link mount parts correctly in place finish weld the components to the axle. Weld all around the point where the original mount meets the new mounts as well as the full length of the gusset where it meets the new and original link mounts (Fig 23). Note: Weld the back side of the gusset for best weld penetration and aesthetics.

FIGURE 23



63. Locate the top of the original stabilizer mount on the passenger's side of the axle. Mark from the front edge of the bracket toward the rear $\frac{3}{4}$ " and mark on the top of the bracket (Fig 24). Make a line along the top of the bracket, parallel to the front face at the $\frac{3}{4}$ " marked distance. This will be a reference line for installing the new stabilizer mount/support gusset.

FIGURE 24



64. Position the new provided stabilizer mount (01354) on the top of the original mount so that the hole is to the driver's side and the front surface is aligned to the line marked on the top of the OE bracket (Fig 25). The stabilizer will butt up to the passenger's side link mount that was just installed.

FIGURE 25



65. Check that the stabilizer mount is perpendicular to the top of the OE mount and position against the link mount and tack weld in place. Double check the position and finish weld the mount to the OE bracket and the link mount.
66. With all welding complete allow the brackets to cool and then paint any raw metal to prevent corrosion.
67. When the paint is dry on the new link mounts, install the provided disconnect ball studs (01302) in the mounts so that the ball portion points toward the center of the vehicle (Fig 26). Install the stud with a $\frac{1}{2}$ " lock nut and two $\frac{1}{2}$ " SAE washers (BP 718), one on each side of the mount. Torque stud to 60 ft-lbs.

FIGURE 26

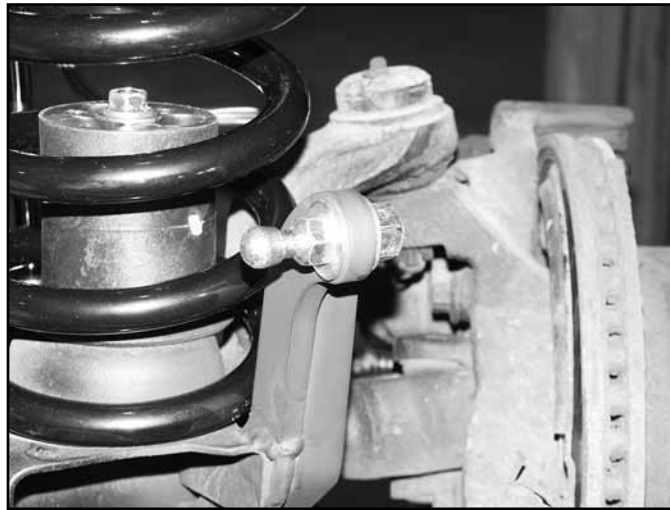

68. The original tapered sway bar link mounting holes in the sway bar must be enlarged slightly to clear a 7/16" bolt. Enlarge the narrow end of the tapered hole to 7/16" with a 7/16" drill or rotary grinding tool.
69. Install the provided upper u-bracket (01325) to the sway bar using the original link mounting hole with a 7/16" x 1-1/2" bolt, nut, 7/16" SAE and 7/16" USS washers (BP 718). Install the bolt up through the u-bracket with an SAE washer into the sway bar. Fasten with the nut and USS washer. Position the bracket so that the thru-holes are parallel with the stud on the axle (Fig 27). Torque to 50 ft-lbs.

FIGURE 27



70. Locate the new provided sway bar disconnect assemblies (A100). Lightly grease and install the provided sleeves (45313) in the bushings.
71. Attach the sway bar link assembly to the upper u-bracket with the provided 3/8" x 2-1/2" bolt, nut and 3/8" SAE washers (BP 718), running from the inside out. Torque bolt to 30 ft-lbs. Leave the sway bar links disconnected at this time.
72. The original tapered track bar mounting hole at the driver's side frame must be enlarged to clear a 9/16" bolt. Drill the tapered hole out with a 9/16" drill bit (Fig 28).

FIGURE 28

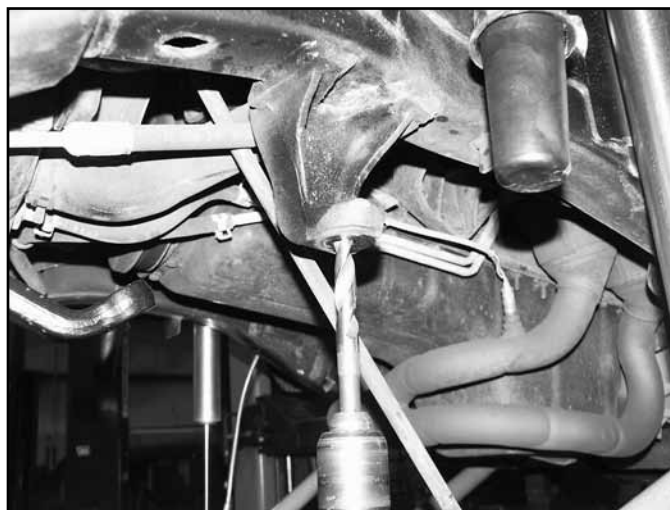

73. Attach the provided front track bar bracket (01359) to the original frame mount with a 9/16" x 2" bolt, nut and 9/16" SAE washer (BP 753). Place the washer on the bolt and run the bolt from the bottom up through the OE mount and fasten with the nut (Fig 29). Note: A washer will not be used on the nut side. Leave hardware loose.

FIGURE 29



74. Rotate the track bar bracket so that the front end fits flush against the bottom of the frame. The front edge of the bracket should be roughly parallel to the welded edge of the steering box mount. The front outside edge of the bracket should be flush with the outside of the frame. Mark the hole to be drill on the bottom surface of the frame (Fig 30A).

FIGURE 30A



75. With the hole position marked for the track bar bracket, rotate the bracket out of the way and drill a 7/16" hole at the mark. Only drill through the bottom surface of the frame. Attach the track bar bracket to the bottom of the frame (Fig 30B) through the new hole with a 7/16" x 1-1/4" bolt, 7/16" SAE washer (BP 753) and provided nut tab (01356). Use Loctite on the bolt threads. Leave hardware loose.

FIGURE 30B



76. With all track bar bracket hardware installed, torque the 9/16" bolt to 95 ft-lbs and the 7/16" hardware to 45 ft-lbs.
77. Locate the new front track bar bracket support tube (01363). There are two support tubes in the kit, one rear and one front. The front support tube is longer (approx. 30").
78. Attach the straight end of the new support tube to the inside of the track bar bracket just installed on the frame. Align the hole in the support with the upper hole in the bracket (above the track bar hole and loosely fasten with a 1/2" x 1-1/2" bolt, nut and washers (BP 766). Before fastening the support tube, make sure the opposite end set relatively flush to the bottom of the passenger's side frame rail. If it doesn't flip the tube over (Fig 31A).

FIGURE 31A

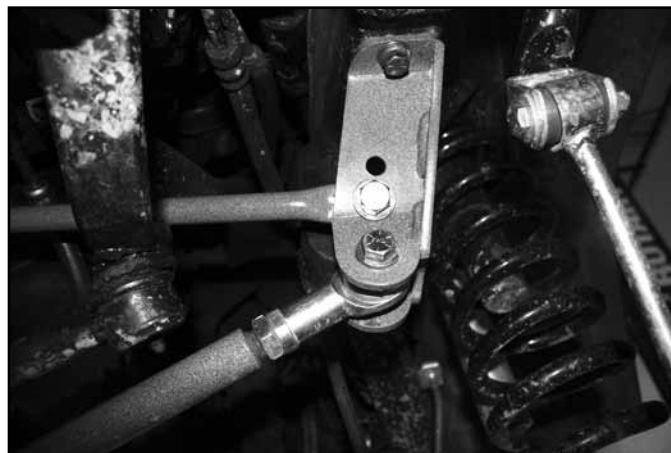

79. With the support tube loosely attached to the track bar bracket on the driver's side, swing it up to the bottom of the passenger's frame rail. Position the end of the tube so that the hole is approximately 5/8" behind the back edge of the existing hole in the frame. Using the hole in the tube as a guide, mark the hole location to be drilled. This hole location will match up with an existing hole in the top of the frame. Lower the tube and drill a 1/2" hole at the mark (Fig 31B).

FIGURE 31B



80. Attach the support tube to the passenger's frame rail through the new lower hole and existing upper hole with a 1/2" x 5" bolt and 1/2" SAE washer (BP 766) run from the bottom up (Fig 31C). Fasten the bolt on the top of the frame with a larger 1/2" washer and nut (BP 766).

FIGURE 31C



81. With both ends of the support tube attached, torque the 1/2" mounting bolts to 60 ft-lbs.
82. Lower the axle and install the provided new front coil springs in the vehicle. When installing the coils, insert a 3" bump stop spacer (3396) in the coil before placing it on the axle mount (Fig 32). Fasten the bump stop spacer with a 3/8" x 4" self-tapping bolt and 3/8" USS washer (BP 754). Use Loctite on the bolt threads and torque to 25 ft-lbs.

FIGURE 32

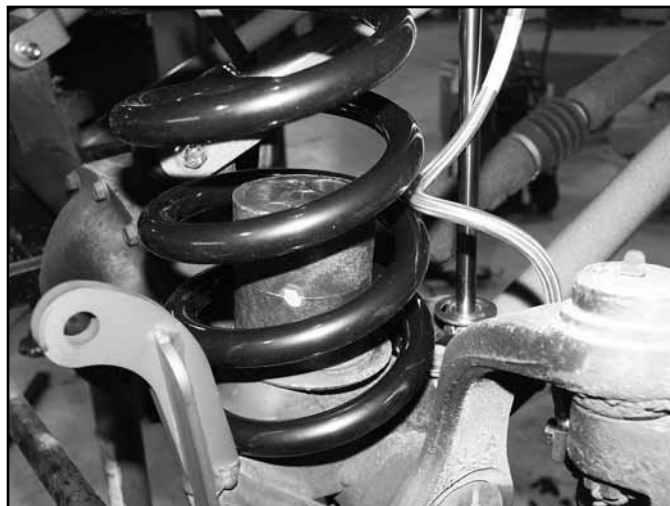

83. Install the new front shocks with the provided upper hardware and OE lower mounting bolts. Torque lower bolts to 20 ft-lbs and upper hardware until the bushings begin to swell.
84. Attach the steering drag link to the pitman arm with the OE nut. Torque nut to 60 ft-lbs and install the new provided cotter pin (BP 754). Do not loosen the nut to install the cotter pin, only tighten.
85. Lightly grease and install the provided bushings (SB58BK) and sleeve (51792) into the steering stabilizer eyes. Install the sleeve in the body end of the cylinder. Install the body end of the stabilizer to the new stabilizer mount on the axle. Fasten the stabilizer with a 1/2" x 2-1/2" button head bolt, nut and 1/2" SAE washer (BP 753). Run the bolt from the back to the front with no washer on the bolt head (Fig 33). Torque bolt to 60 ft-lbs.

FIGURE 33

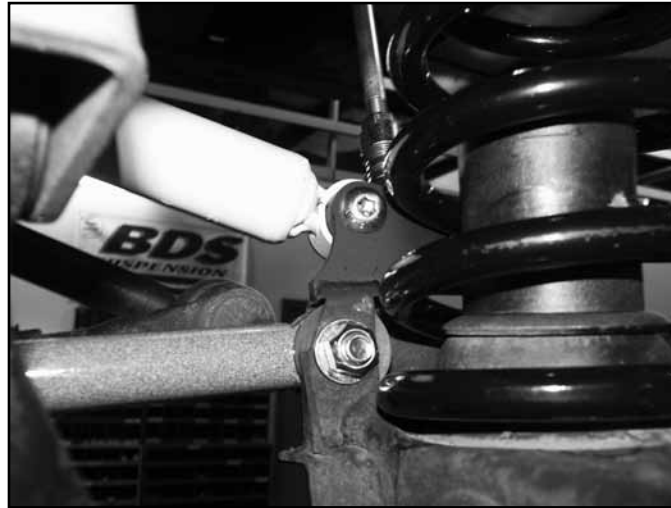

86. Install the provided new stabilizer stud to the drag link in the existing tapered hole. Tighten the stud hardware securely and secure with the provided cotter pin. Attach the stabilizer to the stud and torque to 35 ft-lbs.
87. Lightly grease and install the provide track bar bushings (M02888RB) and sleeve (51792) in the end of the new front track bar (A148).
88. Attach the new track bar assembly to the original steering stabilizer mount so that the track bar runs parallel to the axle to the frame rails. Fasten the bar to the mount with a 1/2" x 2-1/2" bolt, nut and 1/2" SAE washers (BP 753). Leave hardware loose. The frame end will be attached with the vehicle on the ground.
89. Install the wheels and lower the vehicle to the ground.
90. Bounce the front of the vehicle to settle the suspension. Ensure that the axle is centered under the vehicle.
91. Install the provided misalignment bushings (01352) in the end of the track bar rod end. Adjust the track bar end so that it lines up properly with the mounting hole in the frame track bar bracket. Note: The rod end must be threaded on the track bar a minimum of 3/4" for safe operation. This track bar is design specifically for a 6.5" lift and if used properly will provided adequate amounts of adjustment while maintaining a proper amount of thread engagement.
92. With the track bar end adjusted to the appropriate length, attach the end to the track bar bracket with a 1/2" x 3" bolt, nut and 1/2" SAE washers (BP 753). Torque 1/2" mounting bolts at the frame and axle to 65 ft-lbs. Be sure the rod end is square in the bracket and lock off the jam nut securely (Fig 34).

FIGURE 34



93. Torque the front upper control arm pivot bolts at the axle and frame to 40 ft-lbs. Ensure the upper control arm flex end is positioned square in the new bracket and lock off the jam nut securely.
94. Torque the front lower control arm bolts to 95 ft-lbs and lock off the jam nuts.
95. Install the provided coil spring retainers (01379) using the existing holes in the each front coil axle mounts (Fig 35) and 5/16" x 1" self-tapping bolts (BP 754).

FIGURE 35



96. Ensure that the vehicle is setting level. Pull the spring collar up on the sway bar disconnect end and attach it to the ball stud (Fig 36). Make sure that the disconnect end stud hole is square with the ball stud and tighten the jam nut against the disconnect end. The disconnects allow for 1/2" of adjustment (1/2" longer from full-bottomed out). If necessary, adjust the links side-to-side to compensate for any unevenness in the vehicle, allowing for the easiest possible disconnecting of the ends.

FIGURE 36



97. Check the jam nuts to be sure they are securely locked off. Disconnect both end links and fold them up against the sway bar. Clip the provided lanyard/clip assembly around the sway bar/end link and find the best position for mounting the lanyard. This position will vary from vehicle to vehicle and with different suspension setups. Use your best judgment. Use the provided self-drilling screws to mount the lanyard to the body/frame.
98. With the lanyards installed reconnect the sway bar links to the axle. The lanyards can be reattached to themselves so that they remain out of the way of moving parts when not in use.
99. Use provided zip ties to secure the new brake lines away from rotating objects where necessary.

REAR INSTALLATION

1. Block the front wheels.
2. Raise the rear of the vehicle and support the frame rails with jack stands just ahead of the rear bumper.
3. Remove the wheels.
4. Be sure that the axle is well supported. Remove the lower control arms from the axle and the frame. Retain hardware and discard control arms.
5. The rear lower control arm pockets must be removed from the frame to provided clearance for the new long lower control arms. Cut the pockets completely off of the frame using a cut-off wheel and/or reciprocating saw. Take special care not to cut into the frame. Grind that area smooth with a medium grit grinding wheel and paint all bare metal to prevent corrosion.
6. Disconnect the sway bar links from the sway bar and the frame (Fig 37). Discard the links and hardware. Note: If the upper nuts tabs are in good condition they can be reused to install the new sway bar links later.
7. Disconnect the clips retaining the emergency brake cable and rear brake hose to the rear upper control arms (Fig 37).
8. Remove bolt holding the rear brake line to driver's side frame (Fig 37). Retain bolt.

FIGURE 37



9. Disconnect rubber brake line from hard line at retaining clip location.
10. Disconnect the hard lines from brake line junction block on axle.
11. Unbolt the brake line junction block from axle. Retain bolt.
12. Install new BDS rear brake line (22511) in place of the OE. Attach the two hard lines to the junction block and tighten securely. Attach the junction block to the axle with the original bolt. Torque to 20 ft-lbs.
13. Reattach axle breather hose.
14. Attach the new brake line brake (B06103C) to the driver's side frame with the OE bolt. Torque to 20 ft-lbs. Connect the new brake line to the hard line at the frame through the new bracket. Tighten the fitting securely.
15. Install the new brake line retaining clip (5188).
16. Disconnect the emergency brake cable bracket from the bottom side of the body (Fig 38). Retain the mounting nuts.

FIGURE 38

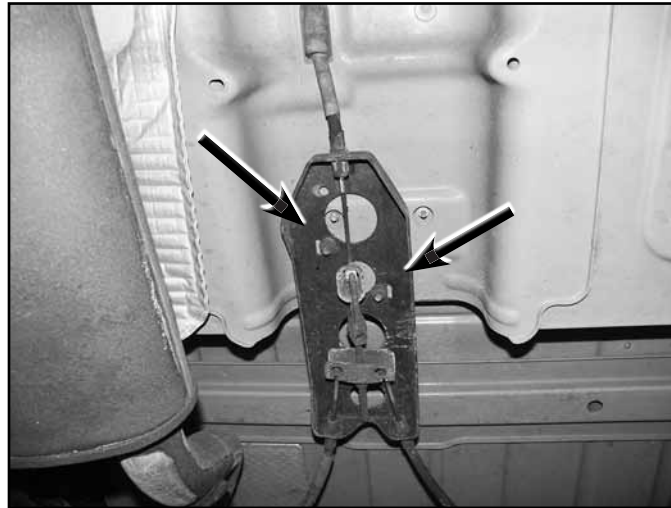

17. Disconnect track bar from the passenger's side frame mount (Fig 39). Retain hardware.

FIGURE 39



18. Remove the rear shocks. Discard shocks and retain hardware.
19. Carefully lower the axle and remove coils.
20. Remove the rubber bump stops from the frame (Fig 40).

FIGURE 40



21. Locate (2) pre assembled long lower control arms (A220). Adjust the length to 29-1/4". Install a provided 90° grease zerk (60107) in the flex end so it faces 45° from down the arm and towards the outside of the vehicle. The arms are installed with the flex eye at the frame with the bend towards the inside of the vehicle.
22. Locate the (2) pre assembled long upper control arms (A222). Adjust the length of the new upper control arms to 25-7/8" (center-to-center). This is a starting point. The length may need to be adjusted at the end of the install for proper driveshaft angles, depending on how the drivetrain is setup.
23. Install the new lower control arms in the OE axle bracket with the original hardware. Swing the flex end of the arm up to the new subframe pocket and fasten with a 9/16" x 4" bolt and 9/16" SAE washer (BP 787). The 90° fitting should be 45 degrees from pointing down the arm and towards the outside. Leave hardware loose.
24. Remove the OE rear upper control arms from the frame and axle mounts. Retain hardware and discard the control arm. Note: Be sure the axle is well supported.
25. Install the new upper control arm Flex eye in the inside subframe pocket (Fig 41) so that the grease zerk is pointing down. Fasten the arm with the 12mm x 80mm bolt (BP 787). Attach the small rubber bushing end of the upper control arm to the OE axle mount with the original hardware (Fig 42). Leave hardware loose. Note: The emergency brake cable should run below the upper control arm and above the sway bar and lower control arm.

FIGURE 41



26. Remove the plastic cover from the track bar mount on the axle (Fig 42). Discard cover.

FIGURE 42

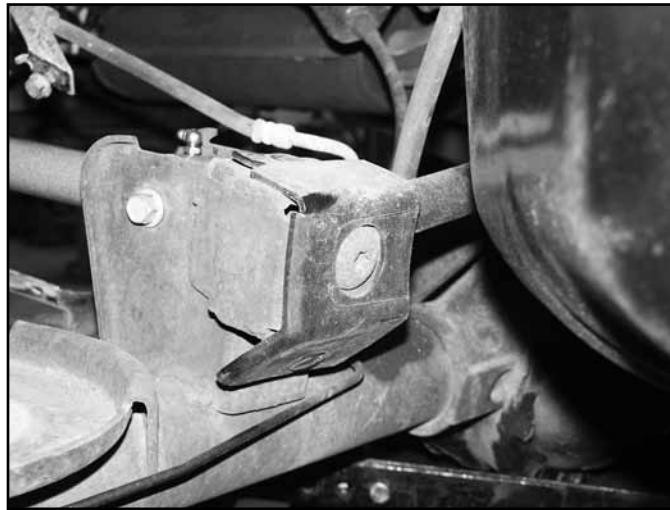

27. Mark the track bar to indicate which end mounts to the axle and the side that faces rearward to aid installation. Disconnect the track bar from the axle mount (a T-55 Torx socket is required). Remove the track bar from the vehicle. Retain the OE nut tab and discard the bolt.
28. Position the new track bar bracket (01332) on the OE axle bracket. Position the bracket so that the top, outside and rear (vertical) surfaces are flush (Fig 43). The bottom mounting tab on the new bracket may not set flush in some cases because of variations in OE brackets, which is OK. Using the bracket as a template, mark the top and outside holes to be drilled. Remove the bracket.

FIGURE 43



29. Locate the existing hole in the lowest surface of the OE track bar bracket. Drill the hole out to 5/16". Locate the mark made on the outside surface of the OE bracket and drill a 1/4" hole. Finally, locate the mark made on the top surface and drill a 3/8" hole.
30. Reposition the new track bar bracket on the axle and fasten through the original track bar mounting hole with a 12mm x 75mm bolt, 1/2" washer (BP 752) and the OE nut tab. Before installing the bolt, position the provided 7/8" OD x 1.600" long crush sleeve (#6) in the bracket and run the bolt through it as well. Leave hardware loose.
31. Install a 3/8" x 1" bolt, nut and 3/8" SAE washers (BP 752) in the 3/8" hole. Install a 5/16" x 3/4" self-tapping bolt in the outside hole and a 3/8" x 3/4" self-tapping bolt (BP 752) in the lower hole (Fig 44). Leave hardware loose.

FIGURE 44

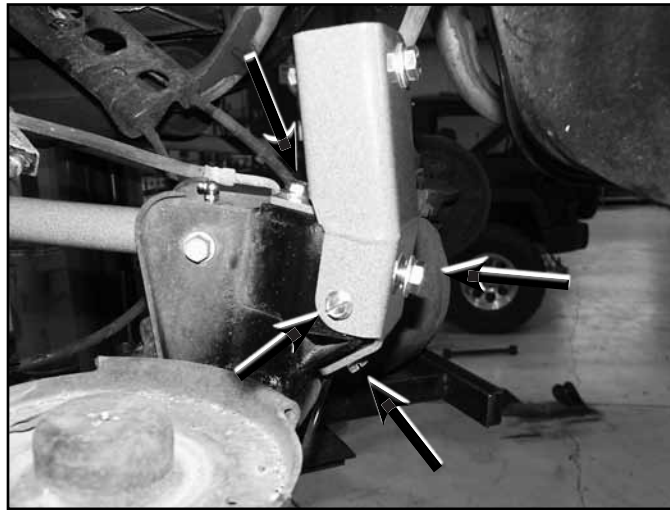

32. With all of the 12mm, 3/8" and 5/16" hardware started, torque all bracket hardware. Torque the 12mm bolt to 65 ft-lbs, 3/8" to 30 ft-lbs and 5/16" to 20 ft-lbs.
33. Loosely attach the provided track bar bracket brace tube (01323) to the remaining hole in the new track bar bracket (Fig 45). Position the brace tube so it attaches to the front side of the bracket and the opposite end of the tube is positioned so that the tab (bent end) rest against the back of the passenger's side upper control arm mount. Fasten the tube to the track bar bracket with a 7/16" x 1" bolt, nut and 7/16" SAE washers (BP 752).

FIGURE 45

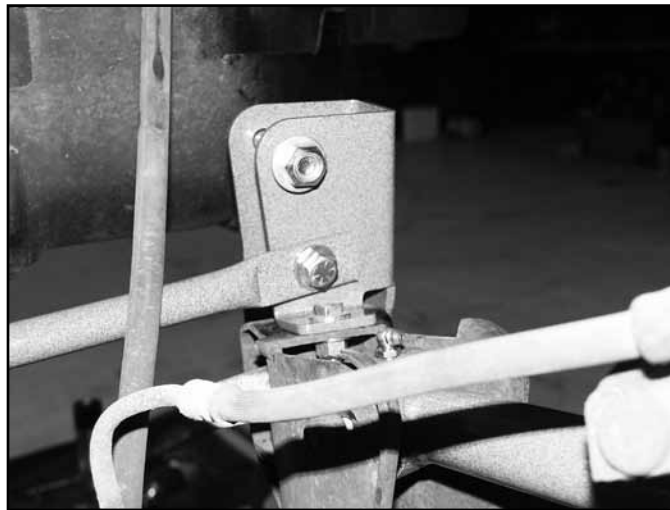
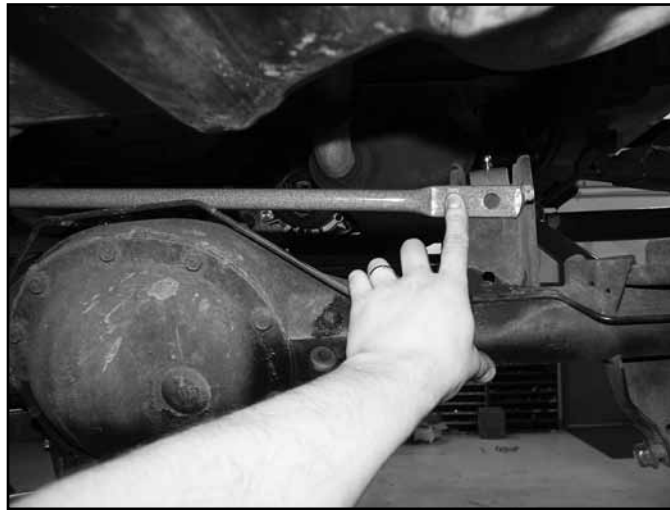

Fig. 46

34. Position the passenger's side of the brace tube against the back of the passenger's side upper control arm mount (Fig 46). The flat edge of the tube end should be roughly flush with the top edge of the upper control arm mount. Mark the position of the tube mounting hole on the mount. Drill a 7/16" hole at the mark. Loosely attach the brace tube to the mount with a 7/16" x 1" bolt, nut and 7/16" SAE washers (BP 752).

FIGURE 46



35. With both end of the brace tube loosely attached, torque the 7/16" hardware to 45 ft-lbs.
36. Using the location marks made earlier, install the original rear track in the new bracket with a 12mm x 75mm bolt, nut and 1/2" SAE washers (BP 752). Leave hardware loose. Be sure that the passenger's side of the track bar runs above the exhaust. It will be attached the frame with the vehicle on the ground.
37. Mount the provided emergency brake cable relocation bracket (01346) to the original mounting studs on the underside of the body (Fig 47). Fasten the bracket with the original nuts and torque to 15 ft-lbs. Note: Mount the bracket so that bend is toward the front and the longer leg of the bracket is down.

FIGURE 47



38. Attach the emergency brake cable bracket to the relocation bracket with 5/16" x 1" bolts, nuts and 5/16" SAE washers (BP 754). Torque bolts to 20 ft-lbs.
39. Locate the OE mounting tabs on the two emergency cables (Fig 48). Using a cut-off wheel, etch the side of the bracket so that it can be easily formed open and removed from the cable. Leaving the cable free at these points will eliminate the chance of binding during extreme suspension articulation. Take care not to cut into the cable.

FIGURE 48



40. Mark the center of the rear coil mounts on the axle (Fig 49). Drill a 5/16" hole in each coil mount. Using a provided 3/8" self-tapping bolt, thread the holes and remove the bolt.

FIGURE 49



41. Grease and install the provided extended bump stops (3529) into the OE bump stop cups in the frame.
42. Install the provided new rear coil springs. Before installing the coils on the lower coil mount, install the provided 3" tall bump stop (3396) in the coil. With the coil in place, fasten the bump stop to the coil mount through drilled/threaded hole made earlier with a 3/8" x 4" self-tapping bolt and 3/8" USS washer (BP 754). Torque to 25 ft-lbs. Use Loctite on the bolt threads.
43. Locate the lower shock brackets (01461). These brackets are designed to offset to the outside of the vehicle on both sides for best gas tank and exhaust clearance. Starting with the passengers side, install the bracket so it offsets to the outside of the factory mount (Fig 50A).

FIGURE 50A - PASSENGER SIDE



FIGURE 50B- PASSENGER SIDE



44. Loosely install the shock relocation bracket in the OE mount to locate the existing hole that lines up with the slot in the new bracket (Fig 50B). Verify the provided 3/8 hardware will fit through the bracket and hole in the axle. If necessary, remove the bracket and drill the factory hole to 7/16".
45. Loosely install the relocation bracket to the factory mount with OE shock hardware and provided sleeve (125) through the original shock mounting hole.
46. Attach the bracket with the provided 3/8" hardware (BP712) through the hole in the OE mount and slot in the bracket. Torque to 30 ft-lbs. (Fig 50C)

FIGURE 50C- PASSENGER SIDE



47. Repeat installation on the driver's side, again with the relocation bracket offset to the outside.
48. Install the shocks in the relocation brackets with the provided 12mm bolts, washers, and nuts. (BP712). Torque the factory bolts and new 12mm bolts to 50 ft-lbs.

FIGURE 51 - DRIVER SIDE



49. On the passenger's side, check for clearance between the rear shock and exhaust tail pipe. This clearance varies from vehicle to vehicle and depends heavily on the rotation of the axle, which is dictated by the pinion angle setup. Mark the area if there is a clearance issue (Fig 52). The exhaust can be rerouted or reworked to clear the shock properly.

FIGURE 52

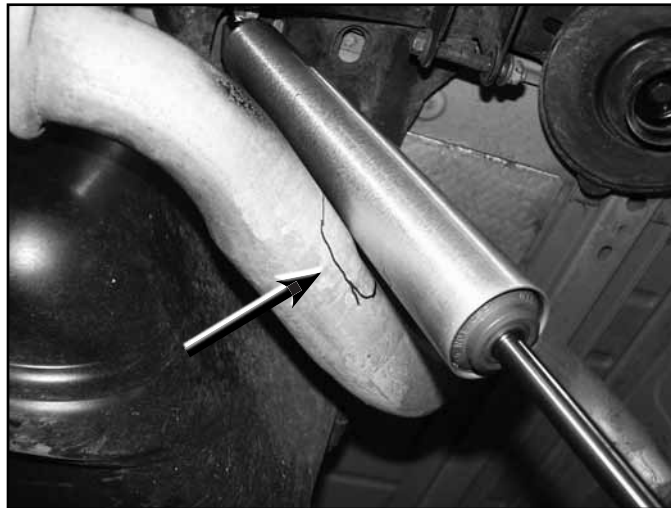

50. Install the provided steel sleeves (45313) in the ends of the sway bar links. Attach the links to the OE frame mount and sway bar using the hardware from bolt pack 709. The OE nut tab for the frame mount can be reused to ease installation (Fig 53). Torque hardware to 30 ft-lbs.

FIGURE 53



51. Install wheels and lower the vehicle to the ground.
52. Bounce the rear of the vehicle to settle the suspension.
53. Torque the rear upper control arm pivot bolts at the axle to 40 ft-lbs. Ensure the upper control arm flex end is positioned square in the new subframe bracket and lock off the jam nut securely.
54. Torque the rear lower control arm pivot bolts at the axle and frame (common upper and lower control arm bolt) to 95 ft-lbs.
55. Connect the track bar to the passenger's side frame bracket with the OE hardware. Torque bolt to 60 ft-lbs.

POST INSTALLATION

56. Completely bleed brake system before driving.
57. Check all hardware for proper torque.
58. Check hardware after 500 miles and any offroad use.
59. Adjust headlights.
60. The control arm ends come pre-greased and therefore are ready for use out of the box. Grease arms after any offroad use and at regular services. Check all control arm/front track bar jam nuts periodically for tightness.
61. A professional front end alignment is recommended to achieve proper steering toe-in and steering wheel alignment. For 98-06 model year vehicles, BDS offers a front alignment cam bolt kit (BDS #124311) for fine tuning alignments if desired. Upper control arm length adjustment will also provide alignment adjust when necessary.
62. Complete a full steering sweep to check tire clearance with the body, frame and suspension components. Depending on the alignment and tire/wheel combo used, the factory steering stops on each steering knuckle may need to be adjusted.

TIME TO HAVE SOME FUN

Thank you for choosing BDS Suspension.

For questions, technical support and warranty issues relating to this BDS Suspension product, please contact your distributor/installer before contacting BDS Suspension directly.



WE WANT TO SEE YOUR RIDE!

Grab photos of your BDS-equipped truck in action and send them in for a chance to be featured. Send it in to our Bad Ass Rides customer gallery at bds-suspension.com/bar and post them on the BDS Fan Page on Facebook at facebook.com/BDSSuspensions. Don't forget about your BDS swag! BDS offers t-shirts, hoodies, decals and more available on the BDS website or through your local BDS distributor.