



491 W. Garfield Ave., Coldwater, MI 49036

Phone: 517-279-2135

Web/live chat: [www.bds-suspension.com](http://www.bds-suspension.com)

E-mail: [tech@bds-suspension.com](mailto:tech@bds-suspension.com)

Part#: **023615**

Product: **6", 8" Suspension System**

Application: **2004-2008 Ford F-150 4wd**

---

## READ AND UNDERSTAND ALL INSTRUCTIONS AND WARNINGS PRIOR TO INSTALLATION OF SYSTEM AND OPERATION OF VEHICLE.

---

**SAFETY WARNING** BDS Suspension Co. recommends this system be installed by a professional technician. In addition to these instructions, professional knowledge of disassembly/ reassembly procedures and post installation checks must be known.

**PRODUCT SAFETY WARNING** Certain BDS Suspension products are intended to improve off-road performance. Modifying your vehicle for off-road use may result in the vehicle handling differently than a factory equipped vehicle. Extreme care must be used to prevent loss of control or vehicle rollover. Failure to drive your modified vehicle safely may result in serious injury or death. BDS Suspension Co. does not recommend the combined use of suspension lifts, body lifts, or other lifting devices.

You should never operate your modified vehicle under the influence of alcohol or drugs. Always drive your modified vehicle at reduced speeds to ensure your ability to control your vehicle under all driving conditions. Always wear your seat belt.

### PRE-INSTALLATION NOTES

1. Special literature required: OE Service Manual for model/year of vehicle. Refer to manual for proper disassembly/ reassembly procedures of OE and related components.
2. Adhere to recommendations when replacement fasteners, retainers and keepers are called out in the OE manual.
3. Larger rim and tire combinations may increase leverage on suspension, steering, and related components. When selecting combinations larger than OE, consider the additional stress you could be inducing on the OE and related components.
4. Post suspension system vehicles may experience drive line vibrations. Angles may require tuning, slider on shaft may require replacement, shafts may need to be lengthened or trued, and U-joints may need to be replaced.
5. Secure and properly block vehicle prior to installation of BDS Suspension components. Always wear safety glasses when using power tools.
6. If installation is to be performed without a hoist, BDS Suspension Co. recommends rear alterations first.
7. Due to payload options and initial ride height variances, the amount of lift is a base figure. Final ride height dimensions may vary in accordance to original vehicle attitude. Always measure the attitude prior to beginning installation.

### POST-INSTALLATION WARNINGS

1. Check all fasteners for proper torque. Check to ensure for adequate clearance between all rotating, mobile, fixed, and heated members. Verify clearance between exhaust and brake lines, fuel lines, fuel tank, floor boards and wiring harness. Check steering gear for clearance. Test and inspect brake system.
2. Perform steering sweep to ensure front brake hoses have adequate slack and do not contact any rotating, mobile or heated members. Inspect rear brake hoses at full extension for adequate slack. Failure to perform hose check/ replacement may result in component failure. Longer replacement hoses, if needed can be purchased from a local parts supplier.
3. Perform head light check and adjustment.
4. Re-torque all fasteners after 500 miles. Always inspect fasteners and components during routine servicing.

# PARTS LIST

Part #	Qty	Description
01085	1	Knuckle (drv)
01086	1	Knuckle (pass)
01087	1	Front Crossmember
01098	1	Front Crossmember Backing Plate
01088	1	Rear Crossmember
01095	1	Differential Skid Plate
01094	2	Compression Strut
01189	2	Compression Strut Mount
32	4	Compression Strut Sleeve
01190	2	Compression Strut Nut Plate
2081BK	8	Compression Strut Bushing
01096	1	Emergency Brake Bracket
01092	1	Differential Support Brace
02000	1	Differential Nut Tab
01089	2	Differential Drop Bracket
01097	2	Sway Bar Drop Bracket
02002	4	Eccentric Cam "D" Bolt
02001	8	Eccentric Cam
N18MPT	4	18mm-2.5 prevailing torque nut
400403	1	1/4" x 15" Differential Vent Hose
01602	1	Rear Brakeline Drop
22524	1	Front Brakeline -DS
22525	1	Front Brakeline -PS
CCW-03-050	4	3/8" Crush Washer
5188	2	Brake Line Retaining Clip
01537	1	PS Rack Relocation Bracket
01090	1	DS Steering Rack Relocation Bracket
01091	2	Steering Rack Spacer
099000	4	Zip Ties
342701	1	Loctite
311	1	Bolt Pack
	3	7/16-14 x 1-1/4" bolt grade 5 clear zinc
	6	7/16" SAE washer clear zinc
	3	7/16"-14 prevailing torque nuts clear zinc

619	1	Bolt Pack
	4	7/16"-14 x 3-1/2" bolt grade 8 yellow zinc
	4	7/16"-14 prevailing torque nut yellow zinc
	12	7/16" SAE flat washer thru hardened yellow zinc
	4	7/16"-14 x 1-1/4" bolt grade 8 yellow zinc
521	1	Bolt Pack
	1	7/16"-14 x 4" bolt grade 8 yellow zinc
	1	7/16" SAE washer thru hardened yellow zinc
	1	12mm-1.75 x 100mm bolt class 10.9 clear zinc
	1	12mm-1.75 x 110mm bolt class 10.9 clear zinc
	2	12mm-1.75 prevailing torque nut clear zinc
	4	12mm flat washer clear zinc
	3	1/2"-13 x 1-1/4" bolt grade 8 yellow zinc
	3	1/2" SAE flat washer thru hardened yellow zinc
	2	5/8"-11 x 5" bolt grade 8 yellow zinc
	2	5/8"-11 prevailing torque nut yellow zinc
	4	5/8" SAE flat washer thru hardened yellow zinc
522	1	Bolt Pack
	4	7/16"-14 x 1-1/2" bolt grade 8 yellow zinc
	4	7/16"-14 prevailing torque nut yellow zinc
	8	7/16" SAE flat washer thru hardened yellow zinc
	6	10mm-1.50 prevailing torque nut clear zinc
	6	3/8" USS flat washer clear zinc
	1	1/4"-20 prevailing torque nut clear zinc
	1	1/4" USS flat washer clear zinc



# INSTALLATION INSTRUCTIONS

## Front Installation

1. Park the vehicle on a clean, flat surface and block the rear wheels for safety.
2. Measure from the center of the wheel up to the bottom edge of the wheel opening and record below:  
LF \_\_\_\_\_ RF \_\_\_\_\_  
LR \_\_\_\_\_ RR \_\_\_\_\_
3. Raise the front of the vehicle and support with jack stands at each frame rail behind the lower control arms.
4. Remove the front wheels.
5. Remove the brake caliper anchor bracket bolts and remove the caliper from the knuckle (Fig 1). Hang the caliper out of the way. Do not let the caliper hang by the brake hoses.

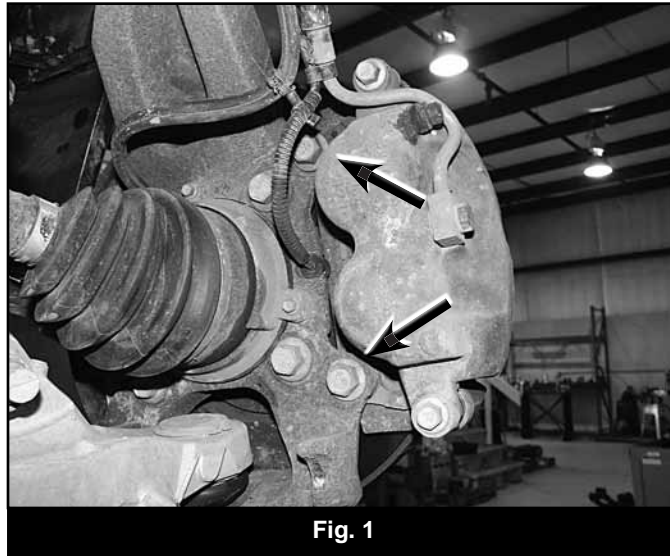

6. Remove the brake rotor and set aside.
7. Disconnect the ABS and hub vacuum lines from the retaining clips (Fig 2).

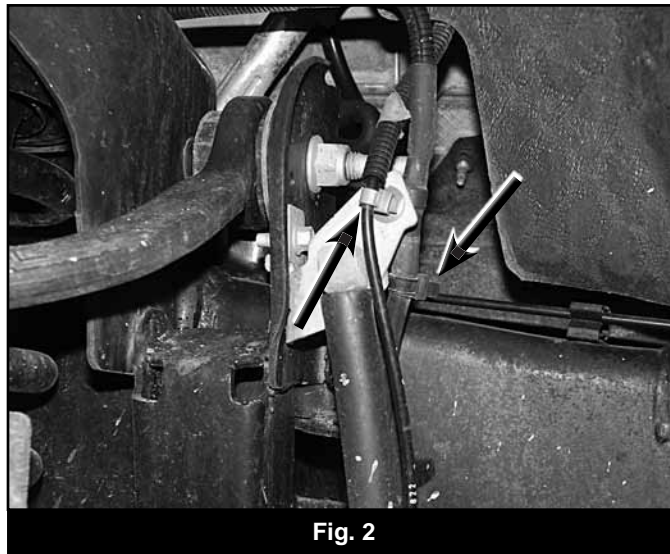

8. Disconnect the hub vacuum line from the hub (Fig 3).

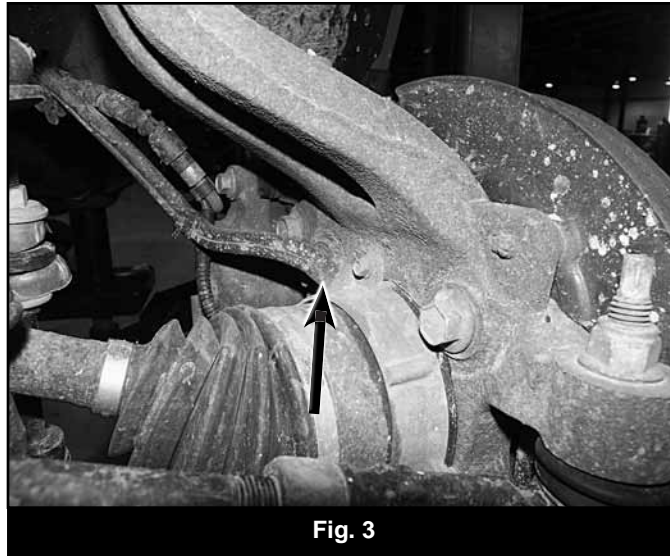

Fig. 3

9. Disconnect the ABS line from the inner fender and disconnect ABS wire connector (Fig 4).

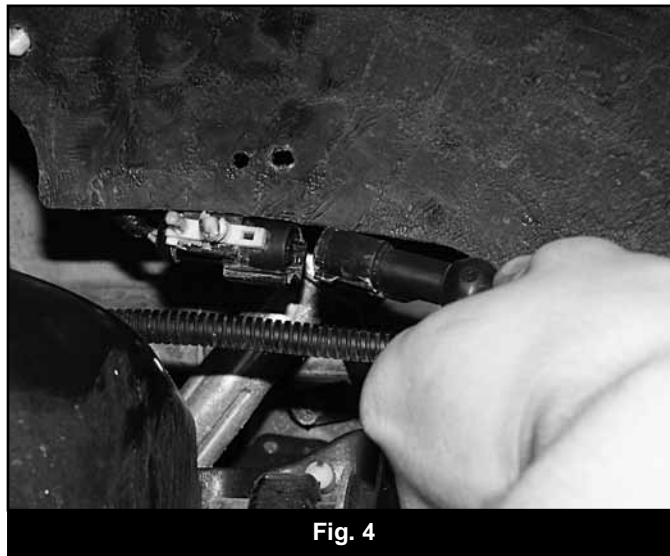

Fig. 4

10. Disconnect the tie rod ends from the steering knuckles (Fig 5). Remove and retain the mounting nuts. Strike the steering knuckle near the tie rod end to dislodge the end. Take care not to strike the tie rod end.

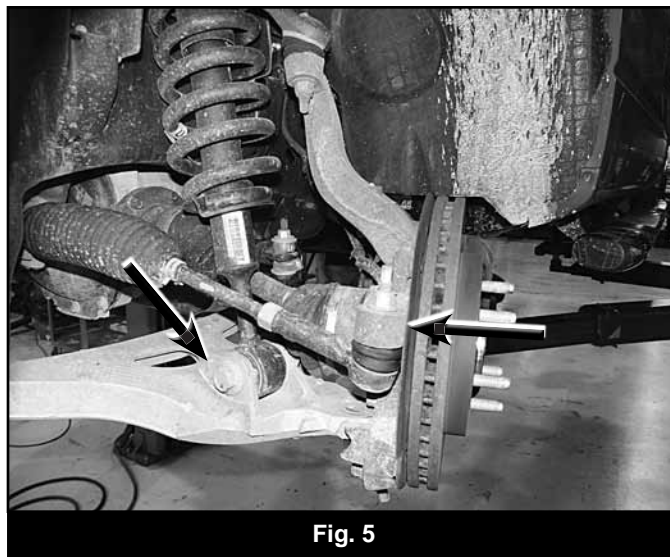
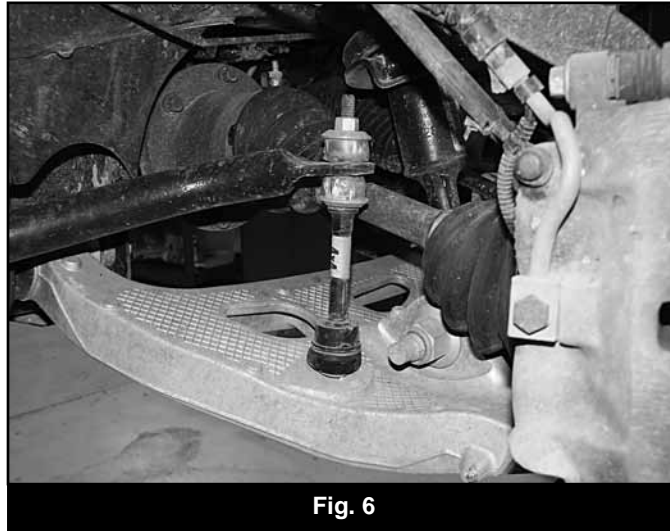
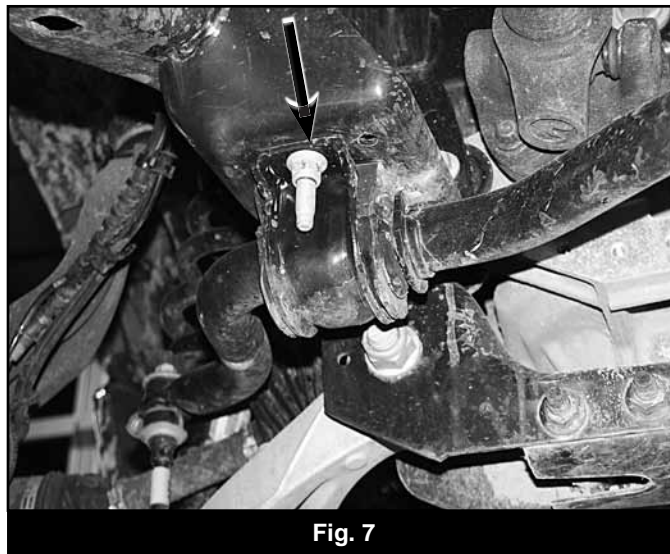

Fig. 5

11. Disconnect the sway bar links from the sway bar (Fig 6). Retain hardware. The sway bar links do not need to be removed from the lower control arms. Note: Different models have different styles. The links will either have a stem or ball joint style mount at the sway bar (stem style shown).



12. Remove the four sway bar mounting nuts and remove the sway bar from the vehicle (Fig 7). Retain hardware.



13. Carefully remove the hub dust cap to expose the axle shaft nut (Fig 8). Remove the nut. Retain the cap and nut, they will be reinstalled later.

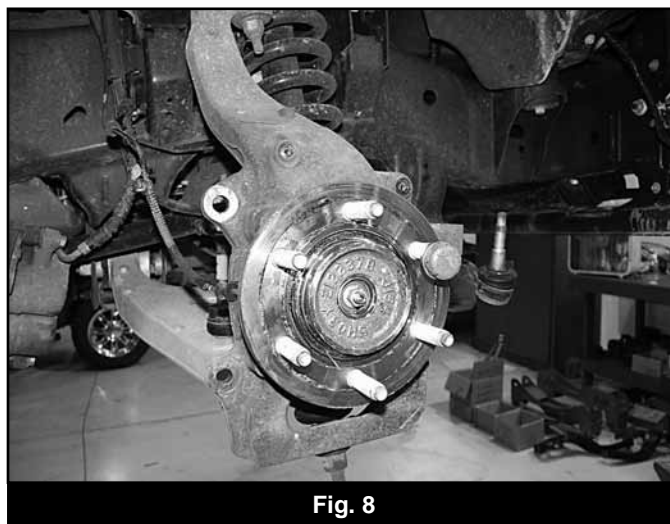

14. Remove the CV axle flange bolts (Fig 9). Retain bolts.

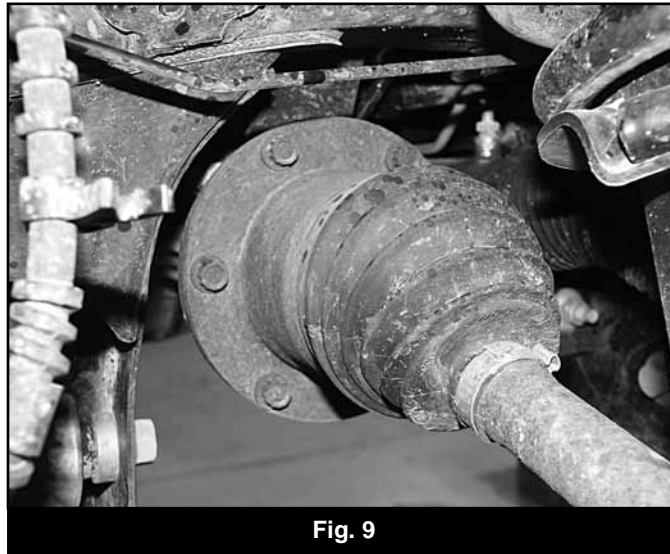

Fig. 9

15. Loosen but do not remove the three strut assembly mounting nuts at the frame (Fig 10). Do not loosen the middle strut nut.

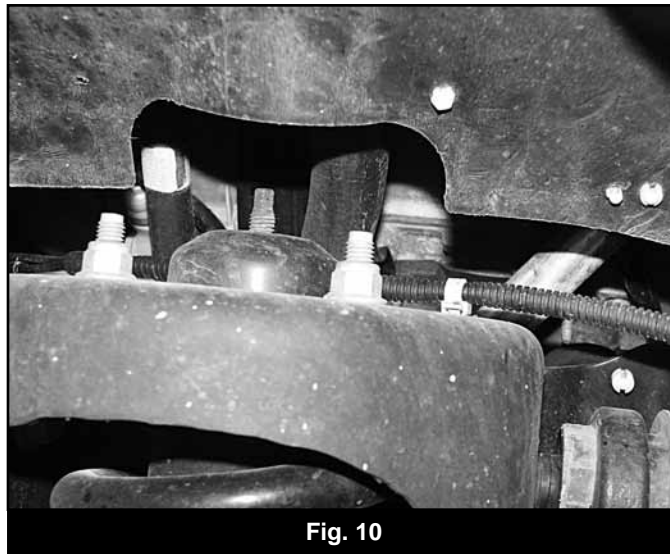
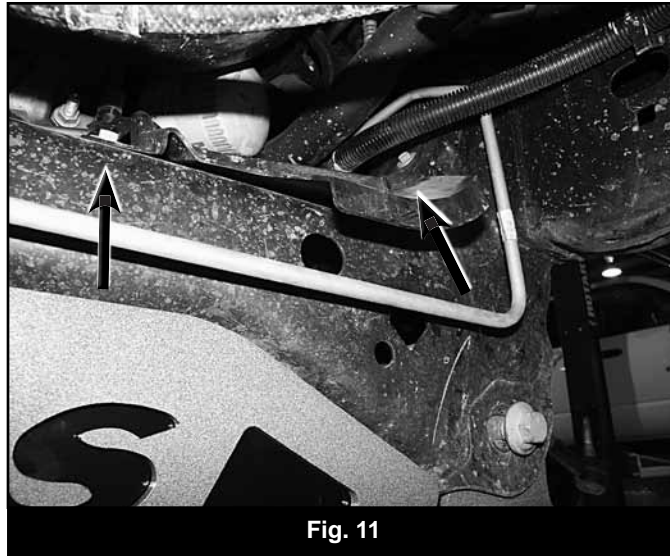
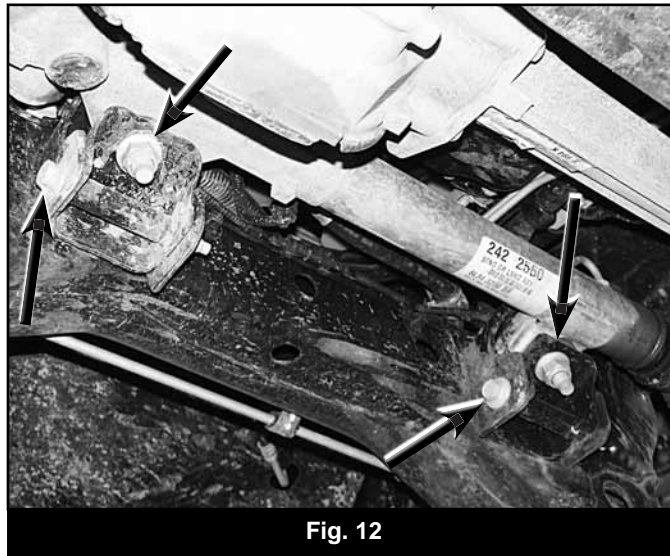

Fig. 10

16. Loosen and remove the nut from the strut-to-lower control arm mounting bolt (Fig 5). Leave the bolt in place at this time. Retain the mounting nut.
17. Remove the upper and lower ball joint nuts (Fig 5) and reinstall a few turns.
18. Strike the knuckle near the upper and lower ball joints to dislodge the joints from the knuckle.
19. Remove the upper ball joint and the strut-to-lower control arm bolt. Swing the knuckle/lower control arm down to remove the CV shaft from the hub. Set CV shaft aside. Retain ball joint nut and strut bolt.
20. Remove the lower ball joint nut and remove the knuckle from the vehicle. Retain hardware.
21. Remove the lower control arm mounting bolts and remove the lower control arm from the vehicle. Retain hardware.
22. Mark the struts to distinguish between driver's and passenger's.
23. Remove the three strut assembly mounting nuts at the frame and remove the strut assembly from the vehicle.
24. Remove the two bolts mounting the oil filter drain shroud to the top of the front frame crossmember. Remove and retain the shroud and bolts (Fig 11).



25. Remove the main vertical rack and pinion mounting bolts (Fig 12). These will not be reused. Remove and retain the horizontal mounting bolts (Fig 12) and remove the rack and pinion support brackets. Discard the support brackets and allow the rack and pinion to hang free.



26. Remove the four bolts mounting the OE rear crossmember to the frame rails (Fig 13) and remove the crossmember from the vehicle. Retain hardware and discard the crossmember.

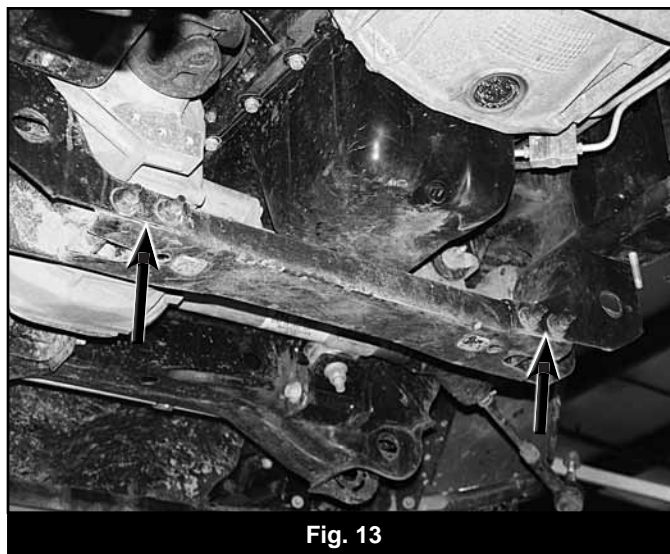

27. Mark the relationship between the driveshaft and the input flange on the front differential. Remove the driveshaft mounting bolts and disconnect the driveshaft from the differential (Fig 14). Allow the driveshaft to rest out of the way. Retain hardware.

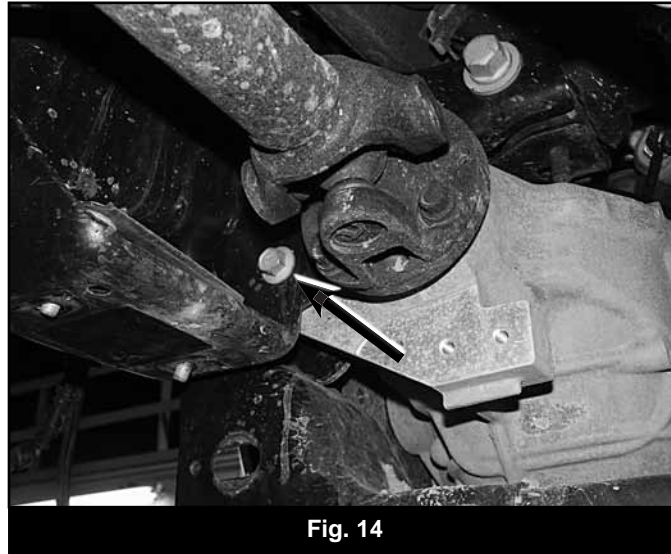

Fig. 14

28. Support the front differential with an appropriate jack. Disconnect the differential breather hose from the differential housing. Remove the two driver's side and one passenger's side differential mounting bolts (Fig 14, 14a, 14b) and remove the differential from the vehicle.

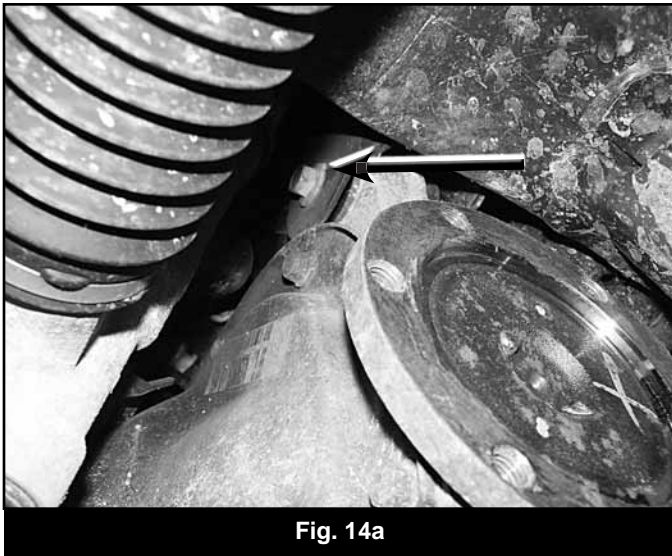

Fig. 14a



Fig. 14b

29. Remove the differential breather hose from the connector up near the frame and replace it with the provided longer one.
30. The driver's side rear lower control arm frame pocket must be modified to provide clearance for the differential in its relocated position. On the front side measure from the inside edge of the control arm slot  $\frac{3}{4}$ " and mark (Fig 15). Make a vertical cut line at the mark.



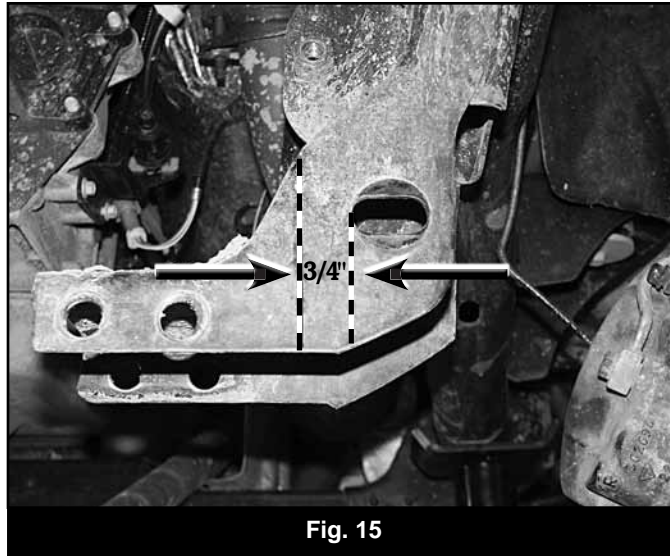

31. On the back side measure from the inside edge of the control arm slot 1-3/4" and mark (Fig 16). Make a vertical cut line at the mark.

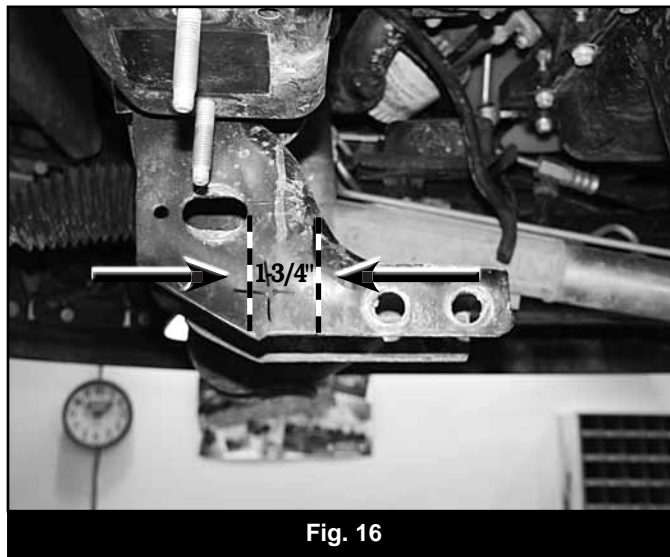

32. Cut out the provided template in this instruction sheet. Line the template up to the rear control arm slot and two crossmember holes. Make a mark for the hole to be drilled as indicated on the template. Remove the template and drill a 1/2" hole at the mark.
33. Install the new rear crossmember (01088) in the rear lower control arm frame pockets and fasten with the OE control arm hardware. Run bolts from front to rear. Leave hardware loose. Ensure the hole that was drilled in the frame pocket lines up to the differential mounting hole in the bracket.
34. Install the new differential drop brackets (01089) in the passenger's side (Fig 17) and front driver's side (Fig 18) OE differential mounting locations with the OE hardware. The brackets should offset toward the front of the vehicle when properly installed. Leave hardware loose.

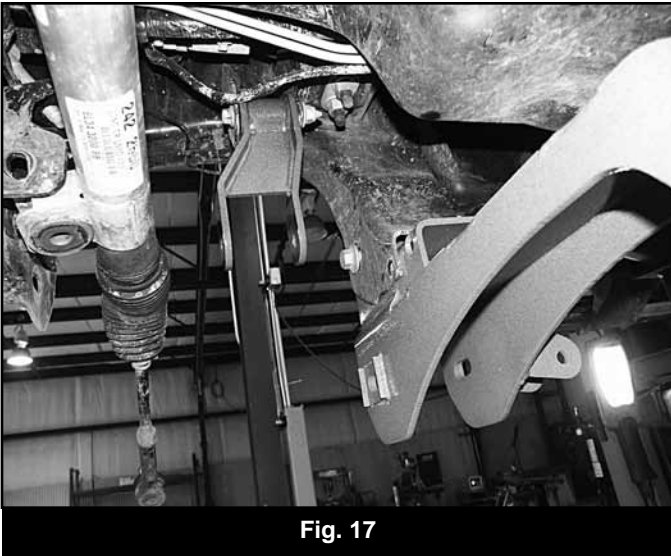

Fig. 17



Fig. 18

35. Install the differential in the vehicle by aligning the differential mounts in the two front drop brackets and in the rear crossmember. Fasten the differential to the driver's front bracket with a 12mm x 100mm bolt, nut and 12mm washers (BP #521). Fasten to the passenger's side bracket with a 12mm x 110 bolt, nut and 12mm washers (BP #521), running from the front to rear. Leave all hardware loose.
36. Fasten the differential to the rear crossmember (Fig 19) with a 7/16" x 4" bolt and 7/16" SAE washer (BP #521) in conjunction with the provided nut tab (02000). Leave hardware loose.

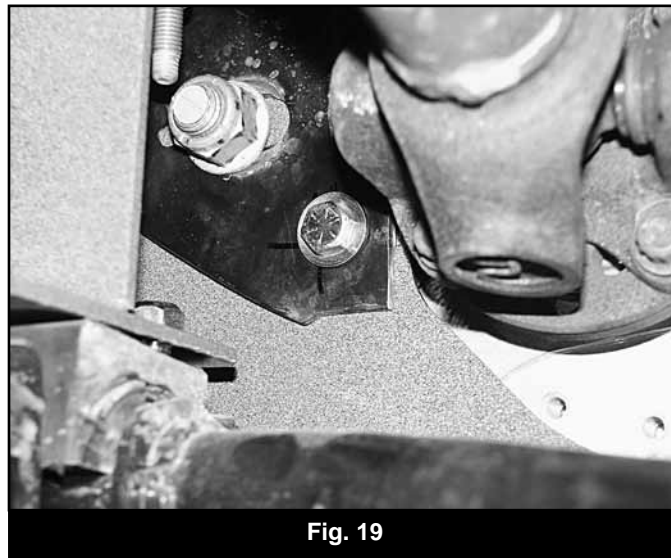

Fig. 19

37. Install the provided differential support bracket to the passenger's side differential bracket using the hardware that was just installed and to the frame where the original rear crossmember mounted with the OE crossmember hardware. Run the OE bolts from rear to front. The support bracket should be positioned so that it is an upside down "U" (Fig 20). Leave hardware loose.
38. Go back and torque all the differential mounting hardware to 50 ft-lbs (7 bolts total). Attach the differential breather hose to the differential.
39. Install the provided passenger's side rack and pinion support bracket (01537) in the original frame mount. The bracket has an integrated stabilizer mount. The stabilizer mount will be closer to the outside of the vehicle. Fasten the bracket to the frame with the OE hardware (Fig 21). Leave hardware loose.



Fig. 20



Fig. 21

40. Install the provided driver's side rack and pinion support bracket (01090) in the original frame mount. The offset plate should be closer to the rack and pinion. Fasten the bracket to the frame with the OE hardware (Fig 22). Leave hardware loose.



Fig. 22

41. Position the provided rack and pinion spacers (01091) between the rack and pinion and the top frame mount (Fig 23, 24 & 25). Install 5/8" x 5" bolts and 5/8" SAE washers (BP #521) down through the frame, spacer, rack and pinion and new support bracket. Fasten the assembly with 5/8" nuts and 5/8" SAE washers (BP #521). Leave loose.



Fig. 23

42. With all of the rack and pinion hardware in place, torque the 5/8" bolts to 120 ft-lbs and the OE bolts to 76 ft-lbs.
43. Reinstall the oil filter drain shroud with the original bolts and tighten securely.
44. Install the provided front crossmember backing plate (01098) on the front crossmember (01087) with 7/16" x 1-1/4" bolts, nuts and 7/16" SAE washers (BP #311) (Fig 24). Torque bolts to 45 ft-lbs. This backing plate is provided in black but can be repainted. This is an optional part in the kit and it is not necessary to install. The purpose is to add a background to the "BDS" cut-out in the crossmember. Note: There will be an extra bolt, nut and two washers left over from bolt pack 311.

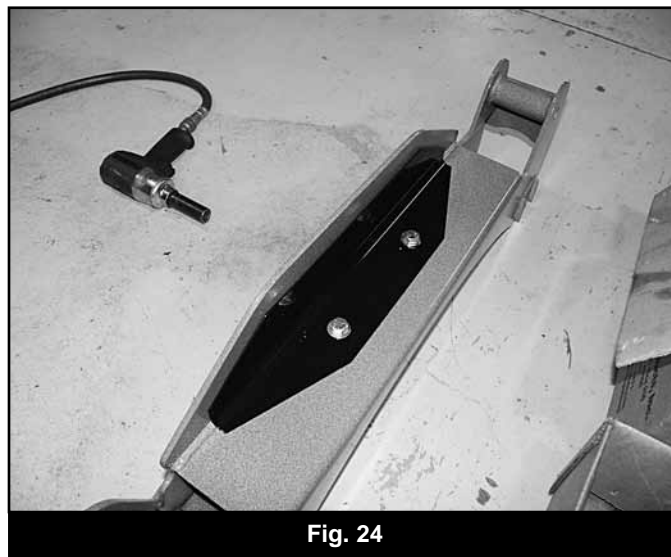

Fig. 24

45. Install the front crossmember in the front lower control arm pockets and fasten with the OE lower control arm hardware (Fig 25). Leave hardware loose.

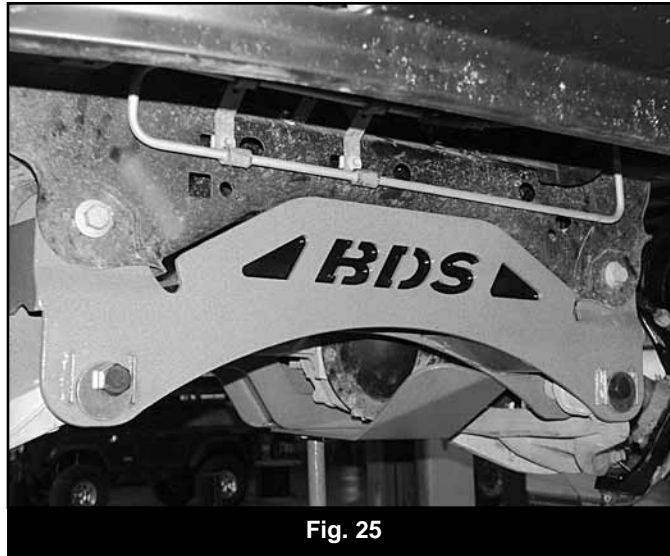

Fig. 25

46. Install the lower control arms in the new crossmembers and fasten with the provided 18mm cam bolts, cam washers and 18mm nuts. Run the bolts from front to rear and leave loose.
47. Install the provided differential skid plate to the front and rear crossmembers with  $\frac{1}{2}$ " x 1-1/4" bolts and  $\frac{1}{2}$ " SAE washers (BP #521) into the weld nuts in the crossmembers (Fig 26). Leave hardware loose.

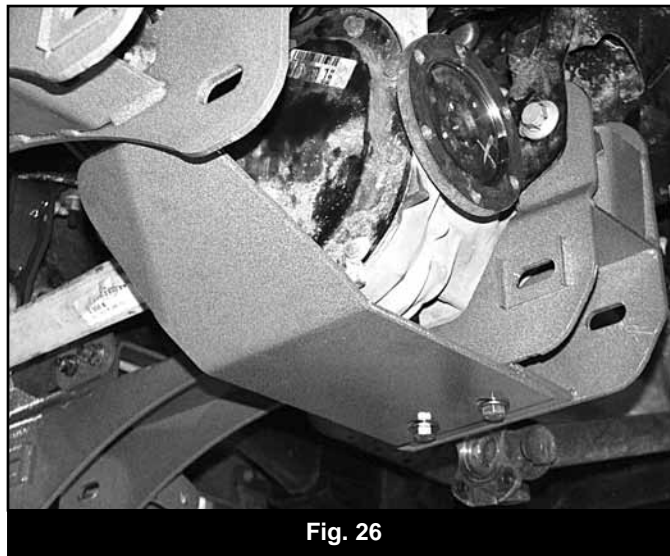

Fig. 26

48. With the lower control arms installed, go back and torque the four crossmember mounting bolts to 222 ft-lbs. Ensure that the front crossmember is centered in the vehicle. Torque the differential skid plate bolts to 65 ft-lbs.
49. Strut replacement: Follow the instruction sheets provided with the appropriate new replacement strut kits (8" - #98180, 6" - #98162)
50. Remove the four hub bolts from the knuckle and remove the hub from the knuckle (Fig 27).

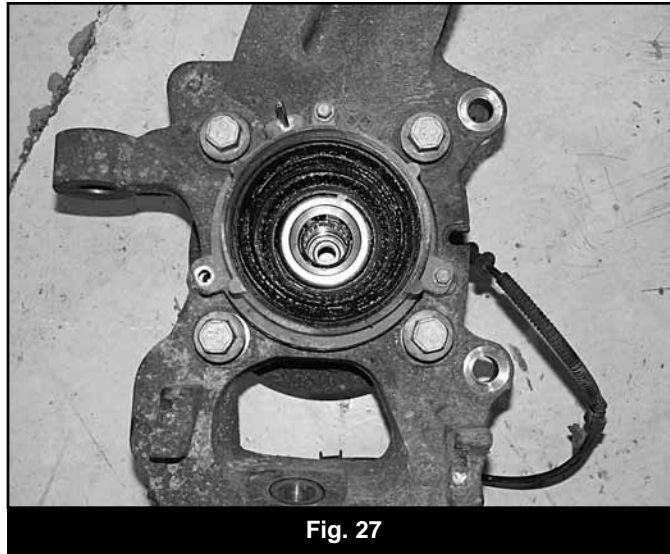

Fig. 27

51. Inspect the outer hub assembly mounting surface and clean any dirt or corrosion off as necessary. Install the hub into the corresponding new BDS knuckle (drv- 01085, pass- 01086) and fasten with the OE bolts. Use Loctite on the bolt threads and torque to 148 ft-lbs. Install the ABS wire grommet in the slot in the knuckle.
52. Remove the three bolts mounting the vacuum hub assembly to the OE knuckle (Fig 27) and reinstall the assembly in the corresponding new knuckle with the OE hardware. Tighten bolts securely (about 5-7 ft-lbs).
53. Remove the duct shield from the OE knuckle and install on the corresponding new knuckle with the original hardware (Fig 28). Tighten securely.



Fig. 28

54. Install the new knuckle assembly on the lower control arm ball joint and loosely fasten with the original nut. Install the CV shaft in the hub, swing the whole assembly up and attach the lower control arm to the strut with the original hardware. Leave all hardware loose.
55. Attach the upper control arm to the knuckle with the original nut. Torque the upper ball joint to 85 ft-lbs and the lower ball joint to 111 ft-lbs.
56. Torque the upper strut nuts to 35 ft-lbs. The lower bolt will be tightened later with the weight of the vehicle on the suspension.
57. Fasten the CV shaft to the hub with the original nut and torque to 20 ft-lbs. Reinstall the dust cap.
58. Attach the CV shaft to the differential output flange with the original hardware. Torque bolts to 60 ft-lbs in a crossing pattern.
59. Install tie rod from top-down. Torque to 111 ft-lbs.

60. Disconnect the OE front brake line from the caliper and retain bolt, discard crush washers. Disconnect the brake line from the hard line at the frame and remove the brake line retain clip to free the brake line from the frame bracket. Retain clip and discard the brake line.
61. Install the new BDS brake line (22524/22525) to the caliper with the OE banjo bolt and two new crush washers (one on each side of the fitting). The brake lines are driver's and passenger's side specific. The end of the brake line should go up and around the bleeder on the caliper. Torque the banjo bolt to 20 ft-lbs.
62. Run the brake hard line through the brake line frame mount and attach the new brake line. Tighten fitting securely.
63. Install the new brake line in the frame bracket and fasten with the OE retaining clip.
64. Install the brake rotor and caliper to the knuckle. Fasten the caliper with the OE bolts and torque to 148 ft-lbs.
65. Attach the ABS line to the connector at the inner fender and the vacuum line to the hub. Route the lines (include the brake line) down the back of the knuckle and attach with zip ties at the upper control arm and knuckle (Fig 29).

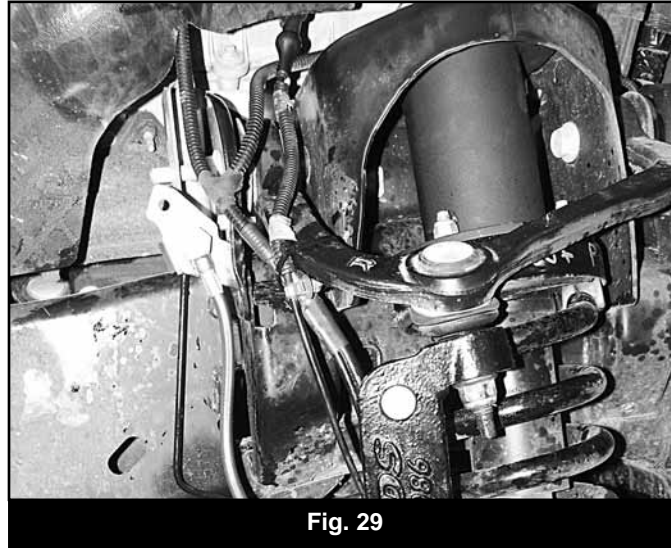

66. Install the provided sway bar drop brackets (01097) to the original sway bar mounting positions with the OE hardware (Fig 30). The open side of the bracket will go to the inside of the vehicle. Torque hardware to 35 ft-lbs.

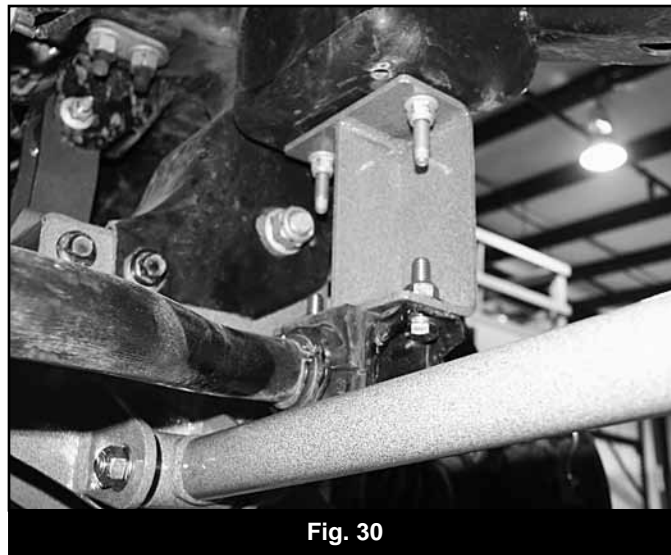

67. Install the sway bar to the new sway bar drop brackets with 7/16" x 1-1/2" bolts, nuts and 7/16" SAE washers (BP #522). Attach the sway bar to the sway bar end links with the original hardware. Torque the 7/16" hardware to 45 ft-lbs. If the sway bar link is a stem style, tighten hardware until the bushings begin to swell. If the link is a ball joint style, torque nut to 45 ft-lbs.

68. Lightly grease and install the provided bushings (2081BK) and sleeves (32-1) in the compression struts (01094). Mount the compression struts to the tabs on the back of the rear crossmember with 7/16" x 3-1/2" bolts, nuts and 7/16" SAE washers (BP #619). Snug hardware.
69. Swing the compression struts up near the transmission crossmember and attach the provided compression strut bracket (01094) to the compression strut with 7/16" x 3-1/2" bolts, nuts and 7/16" SAE washers (BP #619) so that the tabs on the bracket sweep toward the front of the vehicle.
70. The outside hole of the compression strut mount will align with the slot in the OE transmission crossmember. Swing the bracket/compression strut up to the crossmember and using the bracket as a template mark the inside hole to be drill (Fig 31). Lower the bracket and drill a 1/2" hole at the mark.

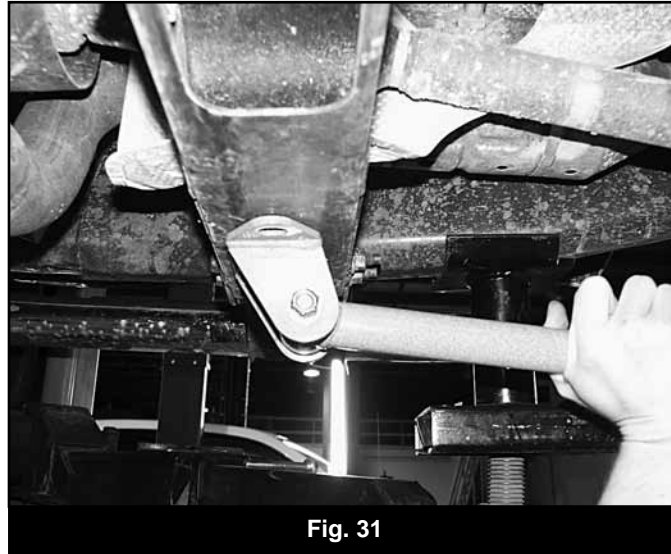

71. Attach the compression strut bracket to the crossmember with 7/16" x 1-1/4" bolts and 7/16" SAE washer (BP #619) with the provided nut tab (01190) inserted into the transmission crossmember through the center access hole. Torque mounting bolts to 45 ft-lbs. Go back and torque all the remaining compression strut bolts to 45 ft-lbs.
72. Reattach front driveshaft to differential. Torque bolts to 76 ft-lbs.
73. Install the wheels and lower the vehicle to the ground.
74. Bounce the front of the vehicle to settle the suspension. Torque the lower strut mount bolt to 350 ft-lbs. Center the lower control arm cams and torque to 150 ft-lbs. tighten upper strut mounting hardware on replacement strut kits to 35 ft-lbs.
75. Check all hardware for proper torque.

## Rear Installation

76. Block the front wheels and raise the rear of the vehicle. Place jack stands under the frame rails ahead of the spring hangers.
77. Remove the wheels.
78. The parking brake cable must be relocated. To disconnect the cable from the frame first pull down on the cable and clamp it off with vise grips near the middle of the frame (Fig 32). This will gain slack to disconnect the driver's side rear cable from the main (passenger's side) cable.





Fig. 32

79. Remove the driver's side parking brake cable from the junction bracket (Fig 33).
80. Compress the retaining tabs and remove the driver's side cable from the spring hanger (Fig 34). It will be relocated and reconnected later.

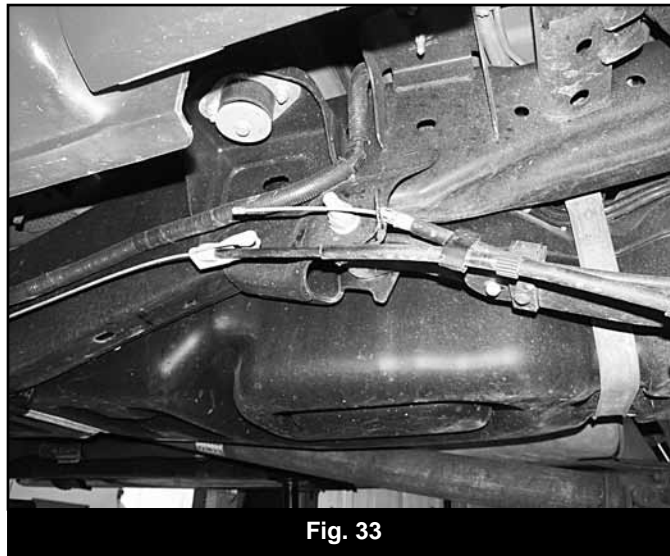

Fig. 33

81. Support the rear axle with a hydraulic jack. Remove the OE shocks. Retain mounting hardware.
82. Disconnect the rear brake line from the frame.

ⓘ *Note: Perform the rear installation on one side at a time.*

### **Block and Add-A-Leaf Kit**

83. Remove the passenger's side u-bolts.
84. Lower the axle and remove the OE lift block, it will not be reused.
85. Using C-clamps, clamp the leaf spring pack together on each side of the center pins. Remove the center pins and discard. Retain the top u-bolt plate on the leaf spring pack.
86. Slowly release the leaf spring pack. Be sure not to mix up the order and orientation of the leaves.
87. Remove the rivets and then remove the two OE leaf alignment clamps. The rivet head can be removed with a grinder, reciprocating saw or air chisel.
88. Install the provided anti-friction pads on the top surface at each end of the provided add-a-leaf (113219).

89. Insert the add-a-leaf in the OE leaf pack where the leaf above it is longer and the leaf below is shorter. Align the center pin holes in the entire pack together (including the top u-bolt plate) with two new center pins. Draw the pack together with C-clamps and tighten the center pins to 50 ft-lbs. DO NOT pull the leaf pack together with the center pins.
90. Install the provided two-piece leaf alignment clamps at each end of the leaf pack.
91. Install the new provided lift block so that the bump stop wing goes toward the inside of the vehicle.
92. Raise the axle/block to the spring while aligning the center pins. Fasten the spring/block assembly with the provided u-bolts, high nuts and washers. Snug u-bolts, they will be torque with the weight of the vehicle on the springs.
93. Repeat installation procedure on the driver's side of the vehicle. Remove the driver's side parking brake cable bracket from the front spring hanger. Remove the front bracket mounting bolt and the nut from the spring bolt and remove the bracket. Retain hardware.

## Leaf Spring

94. Remove the passenger's side u-bolts. Lower the axle away from the spring. Retain the OE lift block, it will be reused.

*Note: In order to remove the front spring hanger bolts the fuel tank and exhaust must be lowered. This kit includes two new replacement 18mm spring hanger bolts. The addition of these bolts to the kit will allow the installer to cut the head of the OE front spring hanger bolt off and pull it out toward the outside of the vehicle. Using this method will eliminate the need to lower the exhaust or fuel tank.*

95. Remove the shackle-to-frame and spring-to-frame leaf spring bolts and remove the spring from the vehicle.
96. Remove the OE shackle from the spring and transfer it to the corresponding end of the new spring (003509). Loosely attach the shackle with the OE bolt.
97. Install the new leaf spring in the vehicle so that the short end of the axle shim is to the front of the vehicle. Fasten the shackle to the frame with the OE bolt and the spring to the front hanger with the OE bolt unless it was cut, in which case use the provided 18mm x 140mm bolt, nut and 18mm washers (BP #523). Leave hardware loose. Note for driver's side: Run the passenger's side emergency brake cable over the top of the spring.
98. Install the OE lift block on the axle so that the bump stop wing is toward the inside of the vehicle.
99. Raise the axle/block to the spring while aligning the center pins. Install the provided spring plate (02032) over the center pins. Fasten the spring/block assembly with the provided u-bolts, high nuts and washers. Snug u-bolts, they will be torque with the weight of the vehicle on the springs.
100. Remove the OE bump stop from the frame and reinstall with the provided bump stop spacer (3396), 10mm x 110mm bolt and 10mm washer (BP #523). Torque bolt to 30 ft-lbs (Fig 34).

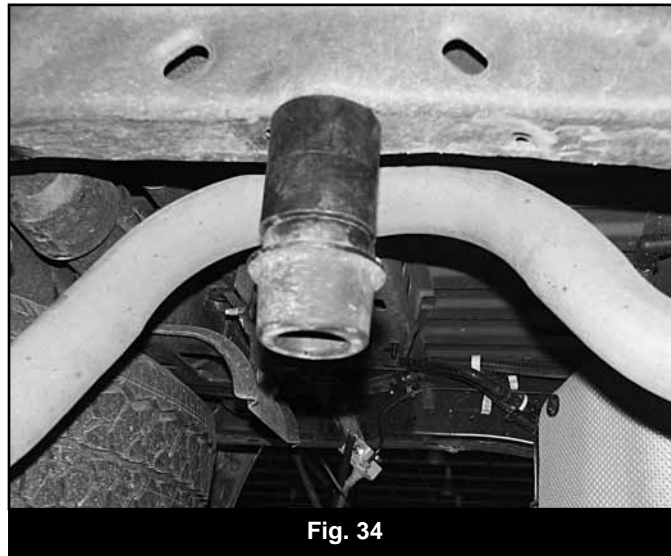

101. Repeat installation procedure on the driver's side of the vehicle. When removing the driver's side front spring hanger bolt also remove the parking brake cable bracket by removing the front mounting bolt. Retain hardware.

## Both Rear Lift Options

102. Install the provided parking brake relocation bracket to the driver's side front spring hanger using the spring bolt. The front tab of the bracket should wrap around the front of the hanger and line up with an existing hole. Fasten the bracket with the OE parking brake bracket bolt and the spring hanger bolt. Torque the smaller bolt to 25 ft-lbs. *Note: If no hole is present, drill center of one slot to 3/8" and attach with 3/8" x 1-1/4" bolt, washers, and nut.*
103. Run the parking brake cable through the relocation bracket and reattach to the parking brake cable junction. When reconnected, remove the clamp to allow the cable to return to its normal tension.
104. Install the provided brake line relocation bracket to the driver's side frame rail with the OE brake line bracket bolt (Fig 35). Torque to 15 ft-lbs.

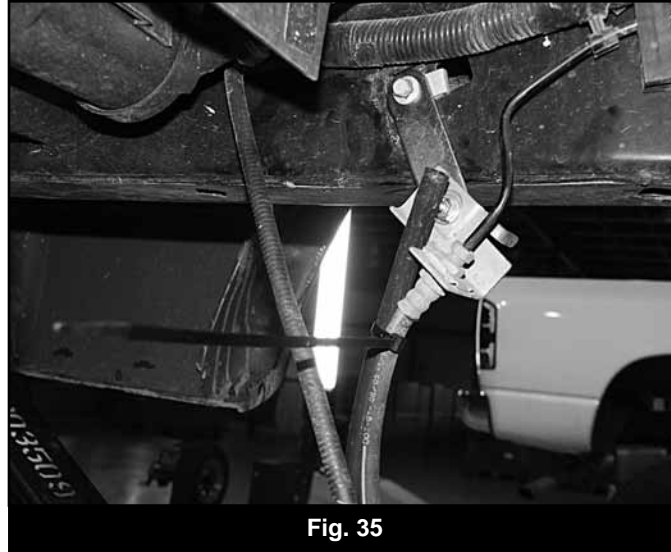

105. Attach the brake line to the relocation bracket with a 1/4" nut and 1/4" USS washer (BP #522). Torque to 15 ft-lbs.
106. Install the provided new BDS shocks with the OE hardware. Torque to 60 ft-lbs.
107. Check all lines/wires for proper slack.
108. Install the wheels and lower the vehicle to the ground.
109. Bounce the rear of the vehicle to settle the suspension.
110. Torque the front spring hanger bolts to 222 ft-lbs. Torque the shackle bolts to 98 ft-lbs.
111. Torque the u-bolts to 100-120 ft-lbs.
112. Check all hardware for proper torque
113. Check hardware after 500 miles.
114. A complete front end alignment is necessary.
115. Adjust headlights.
116. Although unusually rare, if front driveline vibration occurs the front driveshaft must be indexed as shown in the attached figure. The missing spline on the driveshaft must be cut / machined. Use extra caution to not damage the adjacent splines. Thoroughly clean and grease the splines before the driveshaft is reassembled. Reinstall the OE rubber boot with the OE clamp. The driveshaft must be rebalanced before the vehicle is driven.

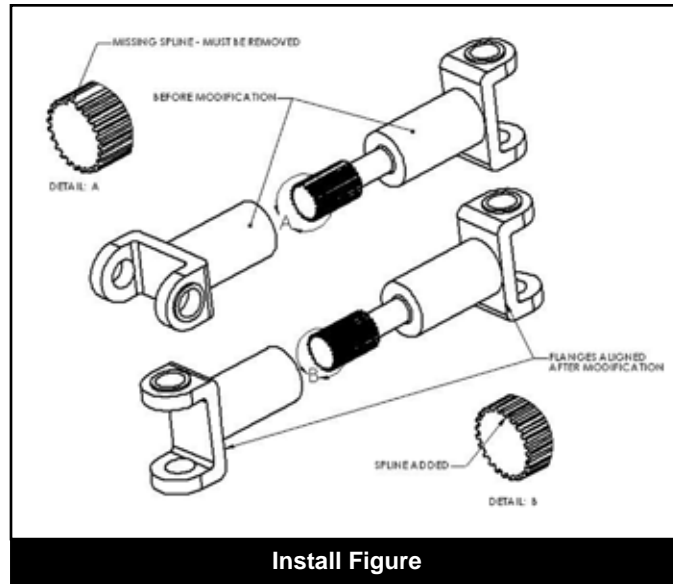

ⓘ *Note: After installation is complete and the vehicle is setting on the ground be sure to inspect the slip on the rear driveshaft. Although highly unusual, certain cab configurations over certain years achieve excessive extension of the rear driveshaft. If this occurs, order rear driveshaft spacer # 123609.*

---

### **NOTICE TO DEALER/INSTALLER**

These instructions, the warning card, and included decals must be given to the owner of this BDS Suspension product.

---

For questions, technical support and warranty issues relating to this BDS Suspension product, please contact your distributor/installer before contacting BDS Suspension directly.

**Sold/Installed by:**

# TEMPLATES

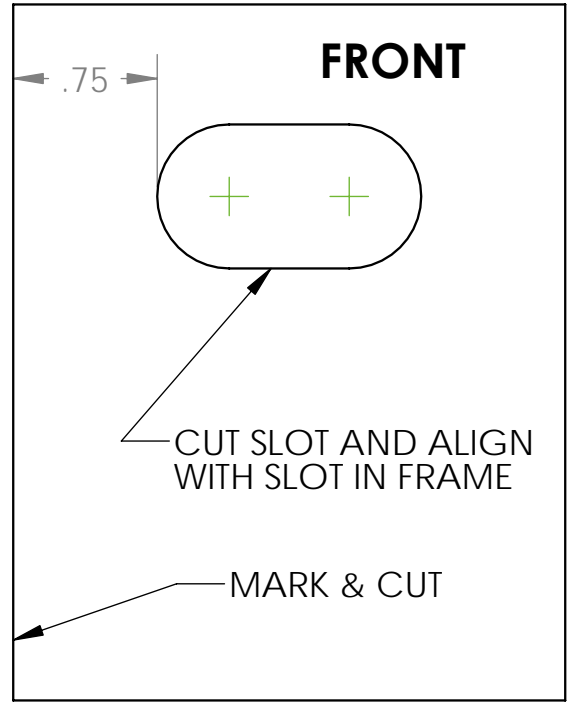
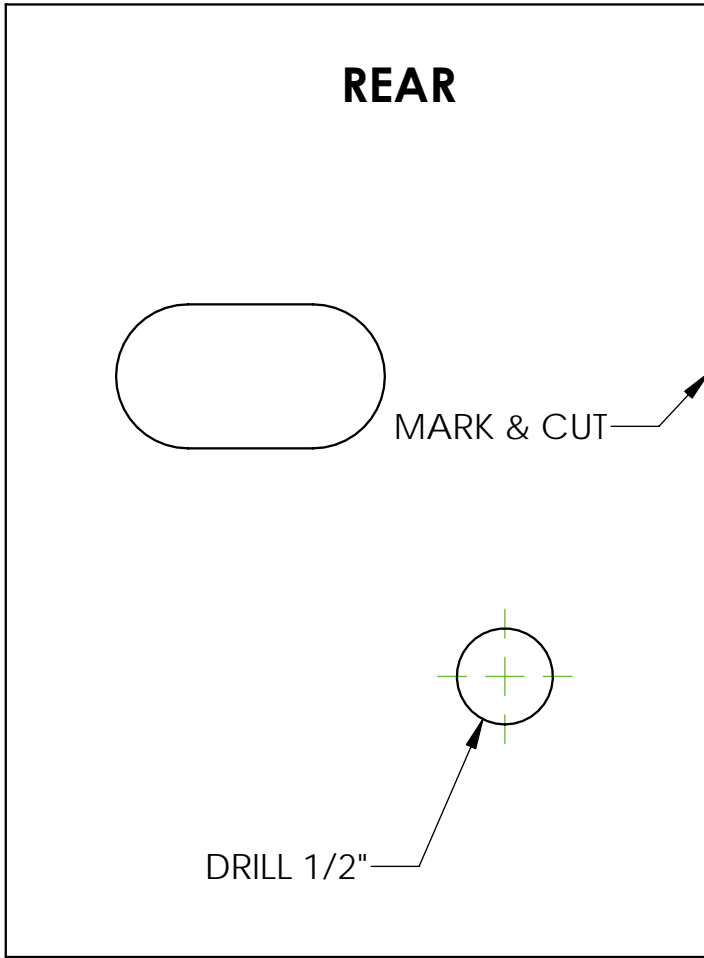

SCALE 1:1 (DO NOT SCALE)