



#C2604 Installation Instructions 2007-2012 Chevy 1/2 Ton 4wd Avalanche, Tahoe, Yukon, Suburban 6.5" Suspension System

Read and understand all instructions and warnings prior to installation of product and operation of vehicle.

Zone Offroad Products recommends this system be installed by a professional technician. In addition to these instructions, professional knowledge of disassembly/ reassembly procedures and post installation checks must be known. Minimum tool requirements include the following: Assorted metric and standard wrenches, hammer, hydraulic floor jack and a set of jack stands. See the "Special Tools Required" section for additional tools needed to complete this installation properly and safely.

» PRODUCT SAFETY WARNING

Certain Zone Suspension Products are intended to improve off-road performance. Modifying your vehicle for off-road use may result in the vehicle handling differently than a factory equipped vehicle. Extreme care must be used to prevent loss of control or vehicle rollover. Failure to drive your modified vehicle safely may result in serious injury or death. Zone Offroad Products does not recommend the combined use of suspension lifts, body lifts, or other lifting devices.

You should never operate your modified vehicle under the influence of alcohol or drugs. Always drive your modified vehicle at reduced speeds to ensure your ability to control your vehicle under all driving conditions. Always wear your seat belt.

» TECHNICAL SUPPORT

Live Chat provides instant communication with Zone tech support. Anyone can access live chat through a link on www.zoneoffroad.com.

www.zoneoffroad.com may have additional information about this product including the latest instructions, videos, photos, etc.

Send an e-mail to tech@zoneoffroad.com detailing your issue for a quick response.

888.998.ZONE Call to speak directly with Zone tech support.

» PRE-INSTALLATION NOTES

1. Special literature required: OE Service Manual for model/year of vehicle. Refer to manual for proper disassembly/reassembly procedures of OE and related components.
2. Adhere to recommendations when replacement fasteners, retainers and keepers are called out in the OE manual.
3. Larger rim and tire combinations may increase leverage on suspension, steering, and related components. When selecting combinations larger than OE, consider the additional stress you could be inducing on the OE and related components.
4. Post suspension system vehicles may experience drive line vibrations. Angles may require tuning, slider on shaft may require replacement, shafts may need to be lengthened or trued, and U-joints may need to be replaced.
5. Secure and properly block vehicle prior to installation of Zone Offroad Products. Always wear safety glasses when using power tools.
6. If installation is to be performed without a hoist, Zone Offroad Products recommends rear alterations first.
7. Due to payload options and initial ride height variances, the amount of lift is a base figure. Final ride height dimensions may vary in accordance to original vehicle attitude. Always measure the attitude prior to beginning installation.

Difficulty Level

easy 1 2 3 **4** 5 difficult

Estimated installation: 7-9 hours

Special Tools Required

Welder

Quality Strut Compressor

Reciprocating Saw or Equivalent

36mm Axle Socket

Tire/Wheel Fitment

33 x 12.50 w/ 17 x 9 & 4.5" BS

34x12.50 w/ 18 x 9 & 5" BS

35x12.50 w/ 20 x 9 & 5.75" BS

Some trimming required

Kit Contents

Qty	Part
1	Steering Knuckle (Drv)
1	Steering Knuckle (Pass)
1	Front Crossmember
1	Rear Crossmember
2	Front Strut Assembly
1	Differential Brkt (Drv)
1	Differential Brkt (Pass)
2	Sway Bar Brkt
1	Differential Skid Plate
1	Crossmember Support Strut
1	Weld-in Plate
2	CV Spacer
1	Bolt Pack - Crossmember Hardware
1	Bolt Pack - Main Assembly
1	Bolt Pack - Differential Mount Hardware
1	Brakeline Brkt (Drv Frt)
1	Brakeline Brkt (Pass Frt)
7	Zip Tie
1	Loctite
2	Rear Coil Springs
1	Rear Track Bar Bracket
2	Rear Bump Stop Extensions
1	Rear Track Bar Support Bracket
2	Rear Sway Bar Links
2	Rear Upper Control Arms
8	Control Arm Bushings
1	Brake Line Spacer Sleeve - 3/4 O.D. x 1.5" long
4	Sway Bar Link Sleeve - 5/8" O.D. x 1.5" long
4	Control Arm Sleeve - 3/4" O.D. x 2" long
1	Track Bar Bracket Sleeve - 7/8" O.D. x 1.7" long
2	Rear Bolt Packs

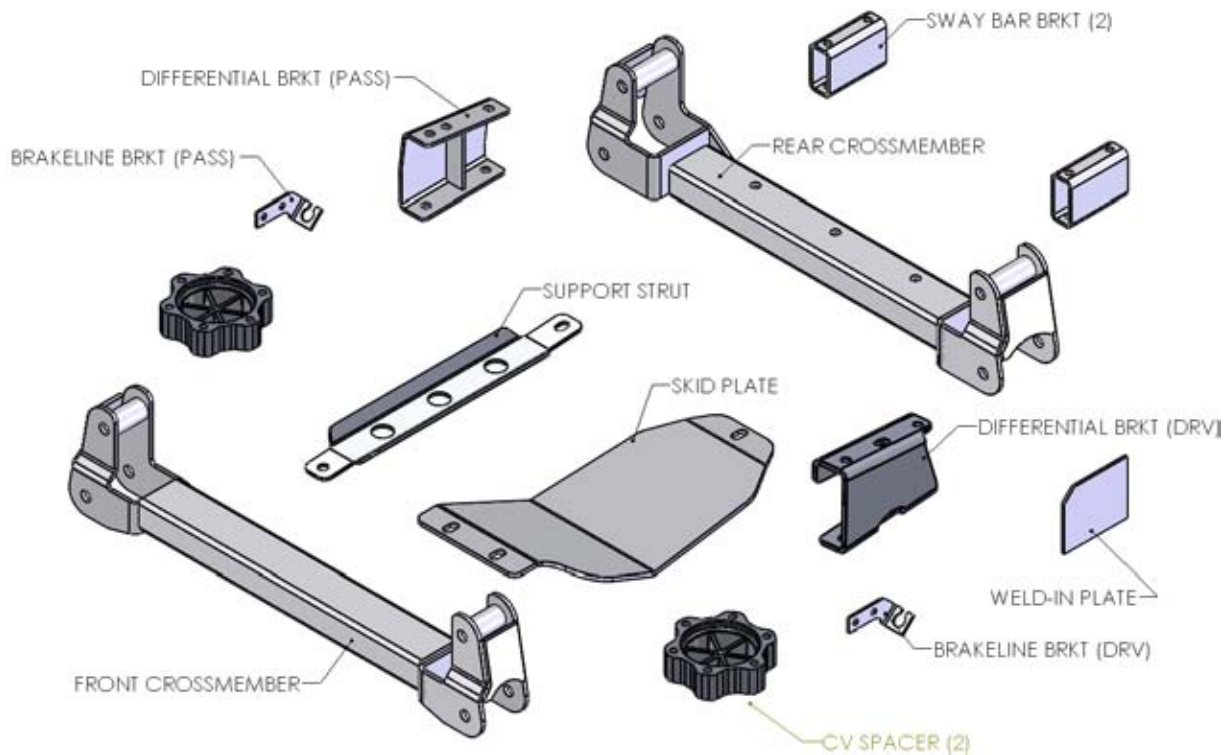

INSTALLATION INSTRUCTIONS

» PRE-INSTALLATION NOTES

1. The installation of this kit requires the use of a good quality coil spring compressor to replace the front coil-over strut. If you do not have a compressor, the strut assemblies can be removed and taken to most any local muffler/service shop and have the struts swapped. The coil springs are under extreme pressure and need to be handled as such.
2. The installation of this kit requires minor welding of a reinforcement plate. We recommend this procedure be performed by an experienced welder. If necessary, this kit can be completely installed and then driven to a shop/welder to have the plate installed/welded. This method will make reaching the weld locations slightly more difficult but it can be done if need be.

» FRONT INSTALLATION

1. Park the vehicle on a clean, flat surface and block the rear wheels for safety.
2. Disconnect the positive and negative battery cables from the battery.
3. Raise the front of the vehicle with a hydraulic jack and support the frame with jack stands just behind the rear lower control arm pocket.
4. Remove the wheels.
5. Disconnect the ABS line from the connector on the frame **Figure 1**. Remove the ABS line from the retaining clips at the frame, upper control arm and knuckle.
6. Disconnect the brake line bracket from the upper control arm **Figure 1**. Save bolt.

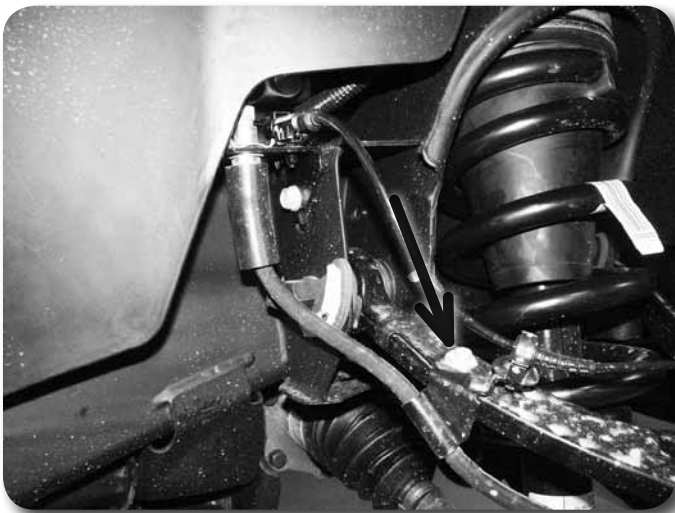

Figure 1

7. Disconnect the steering from the knuckle **Figure 2**. Remove the tie rod end nut. Strike the knuckle near the tie rod end with a hammer to dislodge it. Save the mounting nut.

Important—measure before starting!

Measure from the center of the wheel up to the bottom edge of the wheel opening

LF _____ RF _____

LR _____ RR _____

Step 7 Note

Do not strike the tie rod end with the hammer, only the knuckle.

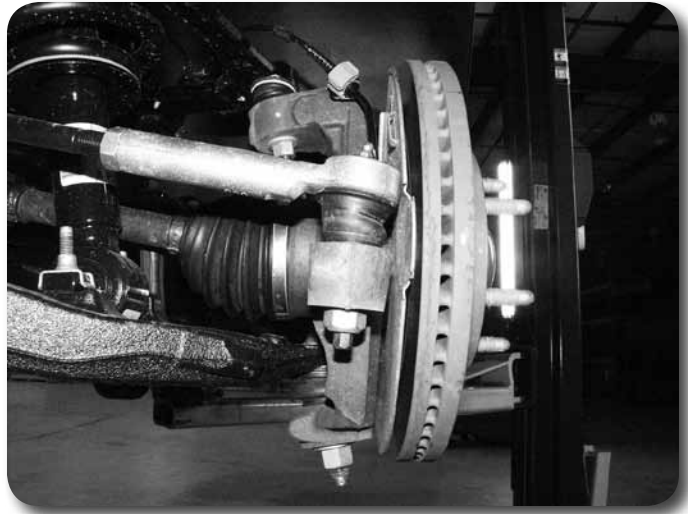

Figure 2

8. Remove the two brake caliper mount bolts and remove the caliper assembly from the knuckle **Figure 3**. Hang the caliper securely out of the way. **DO NOT** hang the caliper by the brake hose. Save caliper bolts.

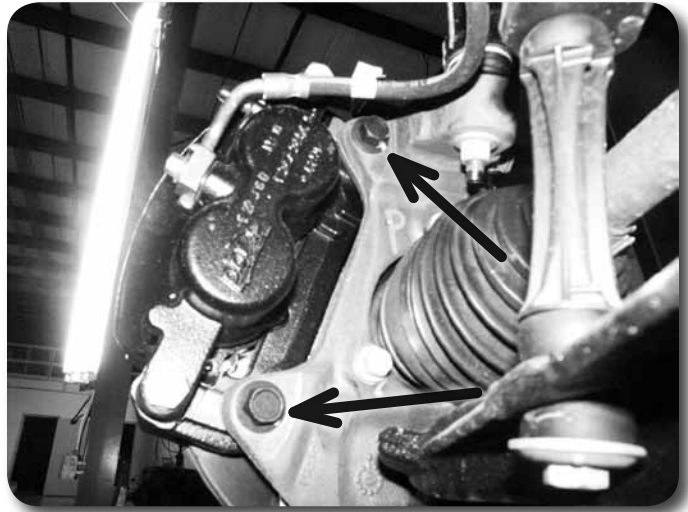

Figure 3

9. Remove the hub dust cap **Figure 4**. Remove the axle shaft nut. Retain nut and cap.

Step 9 Note

Use a small chisel and hammer to carefully separate the edge of the cap from the hub. Work around the circumference of the cap. The axle nut will require a 36mm socket.

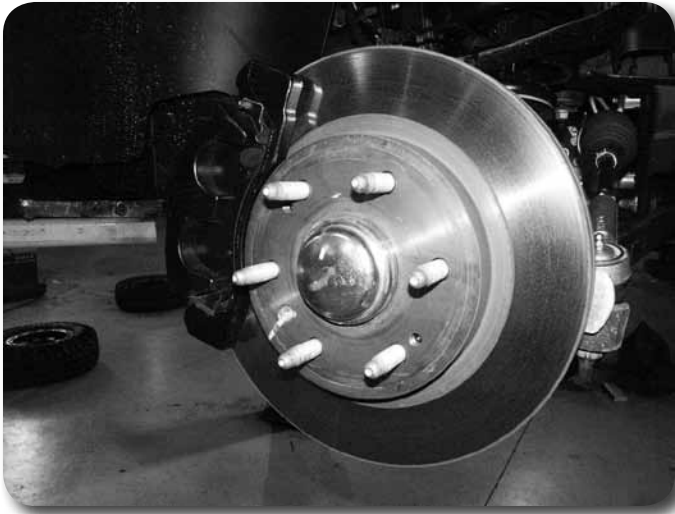

Figure 4

10. Remove the sway bar links from the sway bar and the lower control arm **Figure 5**. Save the links, bushings and hardware.



Figure 5

11. Remove the sway bar from the frame by removing the four bushing cap mounting bolts **Figure 6**. Save all sway bar components.



Figure 6

12. Mark each of the front strut bodies to indicate driver's versus passenger's side. Make the marks on the side of the strut that is facing out.
13. Support the lower control arm with a jack. Remove the lower strut mount bolts **Figure 7**. Save bolts.

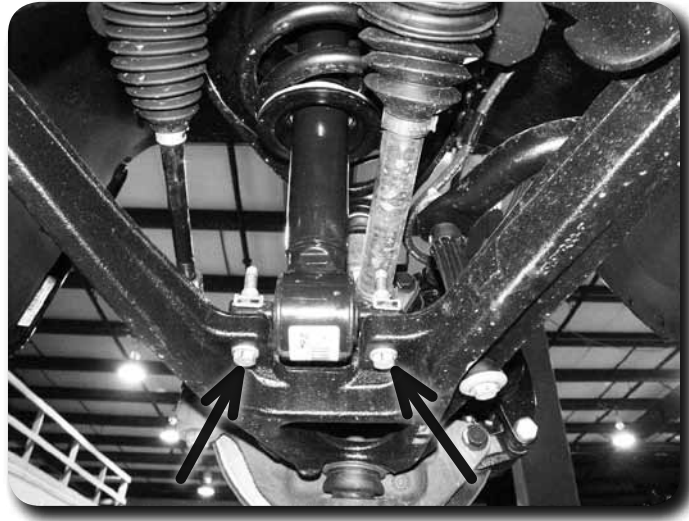

Figure 7

14. Remove the CV shaft mounting flange bolts **Figure 8**. Mark the shaft to indicate driver's or passenger's side. Bolts will not be reused.
15. Remove the upper and lower ball joint nuts and thread back on by hand a couple of turns. Strike the knuckle near the upper and lower ball joints to dislodge them from the knuckle. Remove the upper ball joint nut and lower the lower control arm down. Remove the CV shaft from the hub and set aside. Remove the lower ball joint nut and remove the knuckle assembly from the lower control arm. Save ball joint nuts.
16. Remove the three upper strut mounting nuts **Figure 9** and remove the strut from the vehicle. **DO NOT** remove the center strut rod nut, it is under extreme pressure. Save nuts.
17. Remove the front and rear lower control arm mounting bolts and remove the lower control arm from the vehicle. Save mounting hardware and control arms.

Step 15 Note

Do not strike the ball joints only the knuckle.



Figure 8

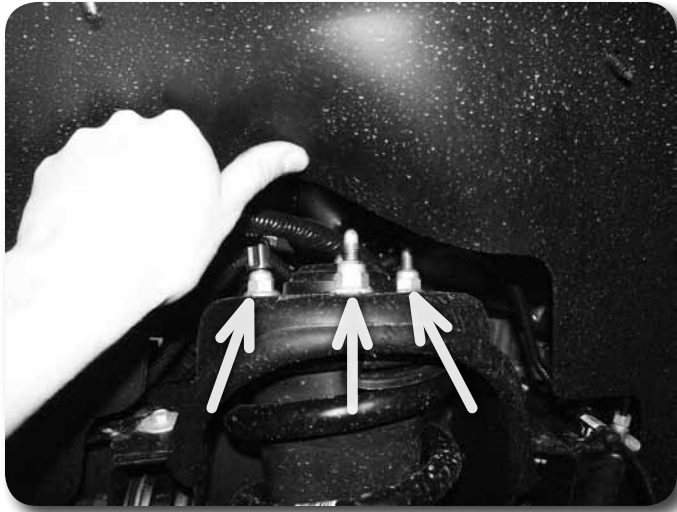

Figure 9

18. Disconnect the differential actuator wire connector from the actuator **Figure 10**. Remove the three wire harness clips holding the actuator harness to the differential housing.

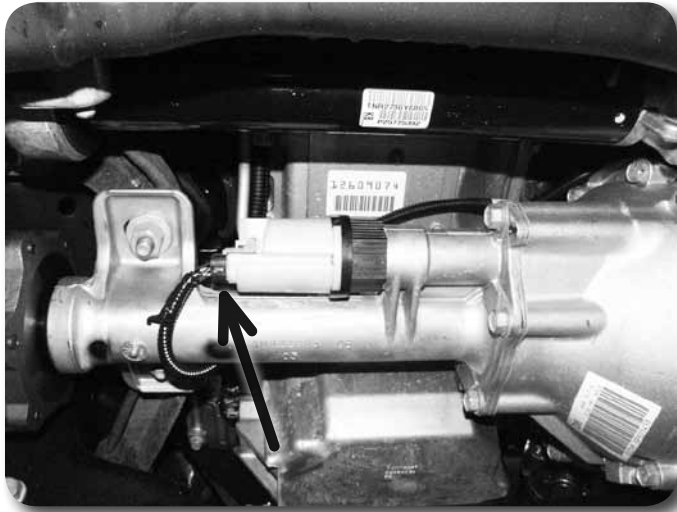

Figure 10

19. Disconnect the differential breather hose **Figure 11**.

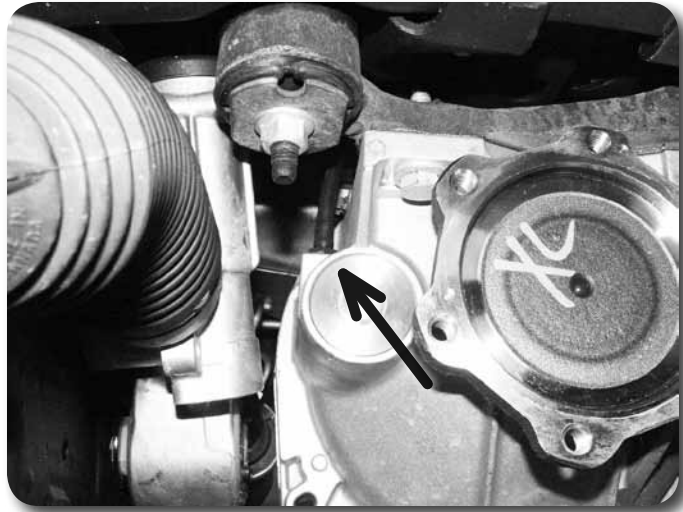

Figure 11

20. Make an alignment mark to show the relationship between the front driveshaft and the differential input flange. Remove the four driveshaft bolts and disconnect the driveshaft from the differential. Save bolts.
21. Remove the four bolts and the factory rear crossmember from the vehicle **Figure 12**. Crossmember and hardware will not be reused.



Figure 12

Step 22 Note

We highly recommend having an assistant to help with removal of the front differential.

Step 23 Note

A putty knife and parts cleaning solvent work well to remove undercoating.

22. Support the front differential with an appropriate jack. Remove the two driver's side differential mounting bolts **Figure 13** and the two passenger's side mounting nuts **Figure 10**. Carefully lower the differential to the ground. Save mounting hardware.
23. The driver's side rear lower control arm pocket must be cut to provide clearance for the front differential in the relocated position. The entire area needs to be cleaned of any oil, grease and/or undercoating. These coatings are flammable.
24. Measure from the inside of the driver's side control arm pocket out 3-1/2" and mark. Repeat this measurement on the opposite side of the pocket. Make vertical cut lines at the 3-1/2" mark up both front and back faces of the pocket **Figure 14**.



Figure 13

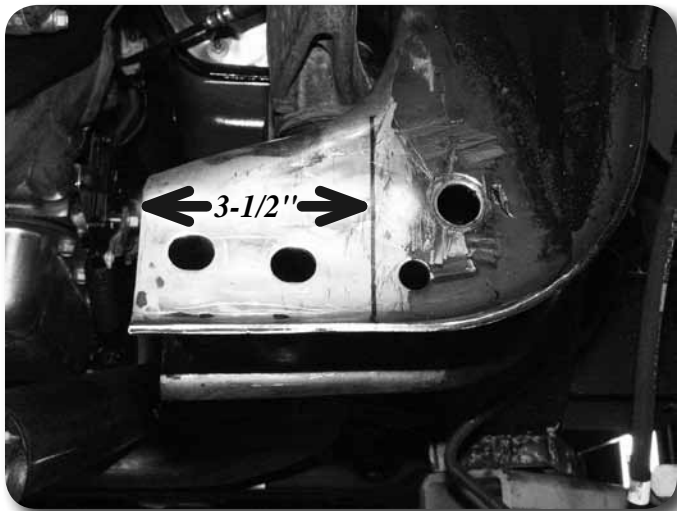

Figure 14

25. Make a vertical cut along each of the cut lines on the front and back faces of the control arm pocket with a reciprocating saw (recommended), cut-off wheel or plasma cutter. Be careful, the undercoating on the frame is flammable and can melt and drip off the frame. Keep an appropriate fire extinguisher near by.
26. With the vertical cuts complete, cut the top portion of the pocket by connecting the two cuts Figure 15.

Step 25 Note

Measure twice, cut once!!!



Figure 15

Step 27 Note

Welding should be performed by an experienced welder. See pre-installation notes at the beginning of these instructions.

27. Place the provided weld-in plate up against the cut edge of the control arm pocket. The plate should be flush with the bottom edge of the pocket and overhang the front and back outside surfaces an equal amount. The chamfered corner of the plate should be in the top-front position **Figure 16**. Tack weld the plate in place.



Figure 16

28. With the plate tacked, go back and weld the plate in place. Weld along the OUTSIDE of the pocket on the vertical surfaces. Welding on the inside will result in crossmember interference. Weld along the top edge of the plate on the inside of the pocket. Once the area has cooled, paint all exposed metal to prevent corrosion.
29. Install the new driver's side differential bracket to the original mount with the factory bolts **Figure 17**. The bracket surface with 3 holes in it goes to the OE mount and the open face points toward the inside of the vehicle. Torque bolts to 65 ft-lbs.

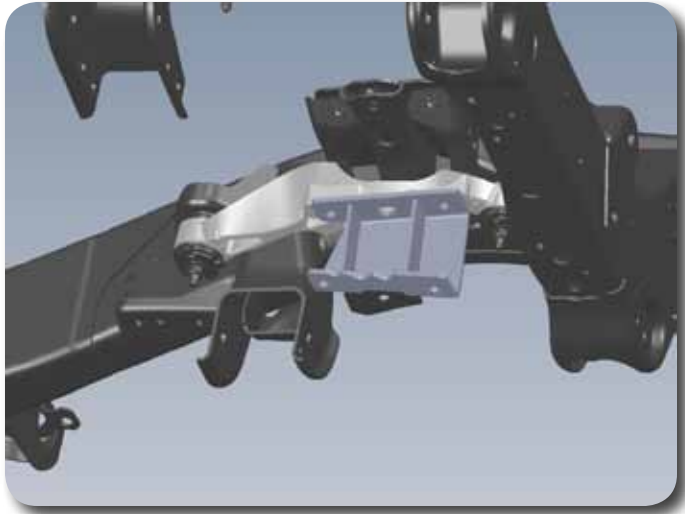

Figure 17

30. Install the new passenger's side differential bracket to the original mounting studs with the factory nuts **Figure 18**. The bracket mounting surface with 3 holes in it goes to the frame and the open face toward the inside of the vehicle. Torque nuts to 65 ft-lbs.

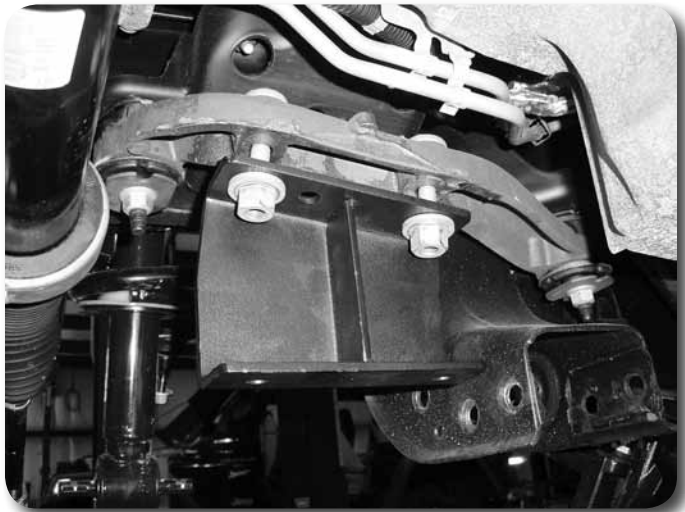

Figure 18

31. The small corner of the differential housing that will rest closest to the new weld-in plate needs to be slightly trimmed **Figure 19** to provided adequate clearance when installed. Only about 3/8" of material needs to be removed along the length of the corner. The trimming can be done with a reciprocating saw, hack saw or grinder. Measure from the top corner and mark 3/8" in both directions. Extended the cut lines down along the housing.

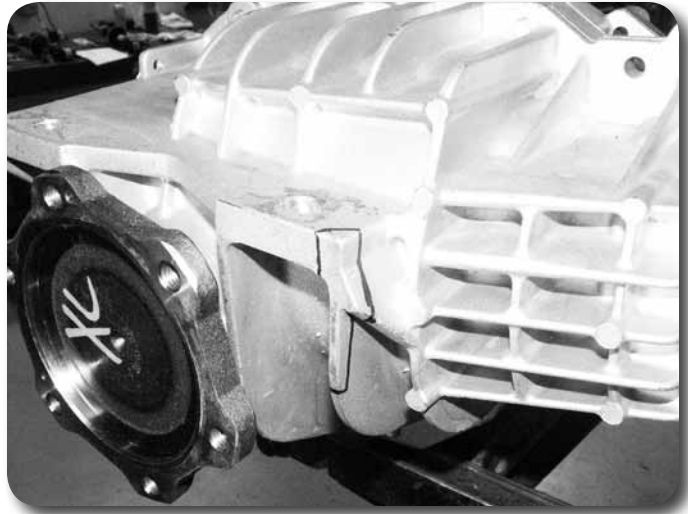

Figure 19

Step 32 Note

Hardware for the differential drop brackets is located in hardware pack #644.

32. Using an appropriate jack, install the differential in the vehicle by attaching it to the new driver's and passenger's differential brackets. Fasten the differential to the brackets with $\frac{1}{2}$ " x $1\frac{3}{4}$ " bolts, nuts and washers. Use two $\frac{1}{2}$ " SAE washers on each bolt for the driver's side. Use one $\frac{1}{2}$ " SAE washer and one extra large $\frac{1}{2}$ " washer on the passenger's side. The extra large washer will go against the differential housing flange with the large slots **Figures 20A & B**. Torque the $\frac{1}{2}$ " hardware to 65 ft-lbs. Pull the differential forward as the passenger's side bolts are tightened.

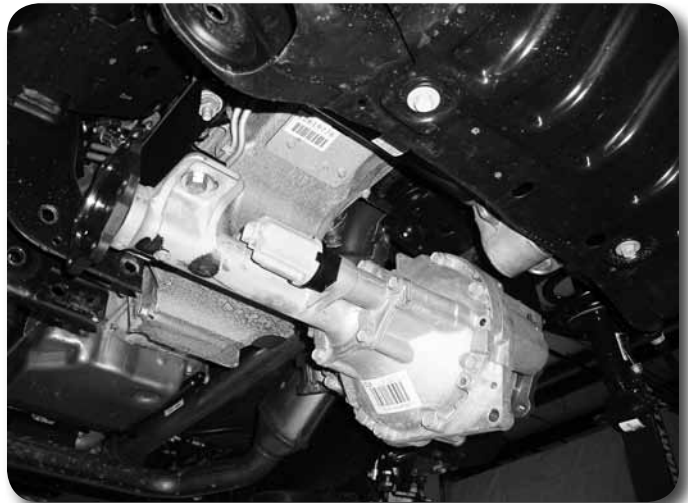

Figure 20A

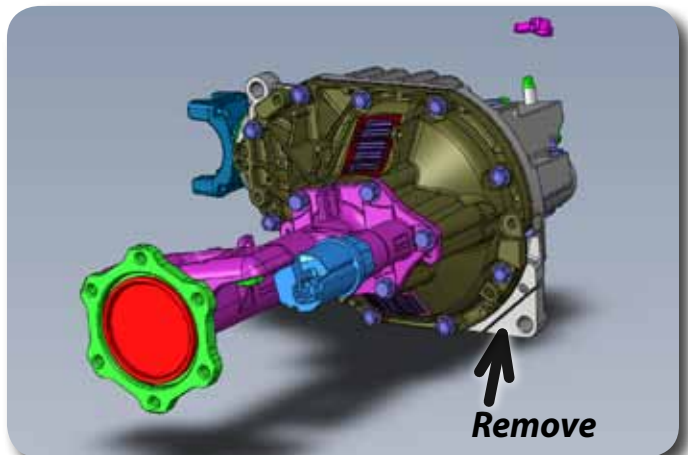

Figure 20B

33. The front tab on the differential must be removed for skid plate clearance. Use the template on the last page of the instruction sheet to mark the area to be removed. Remove material with a hacksaw, sawzall, or cutoff wheel. Do not cut into the main differential housing!
34. Reconnect the differential actuator wiring. Reattach the wire to the differential housing with the provided wire ties.
35. Reconnect the differential breather line. The line will need to be removed from retaining clips above to gain slack.
36. Reconnect the front drive shaft to the differential with the original hardware. Torque bolts to 19 ft-lbs.
37. Install the new rear crossmember with the factory lower control arm bolts, nuts and washers. When installed the rectangular cross tube should offset closer to the rear of the vehicle **Figure 21**. Run the bolts from front to rear. Leave hardware loose.
38. Install the front crossmember in the control arm pockets with the factory lower control arm bolts, nuts and washers. When installed the offset in the crossmember ends should be toward the front of the vehicle **Figure 21**. Run bolts from front to rear. Leave hardware loose.

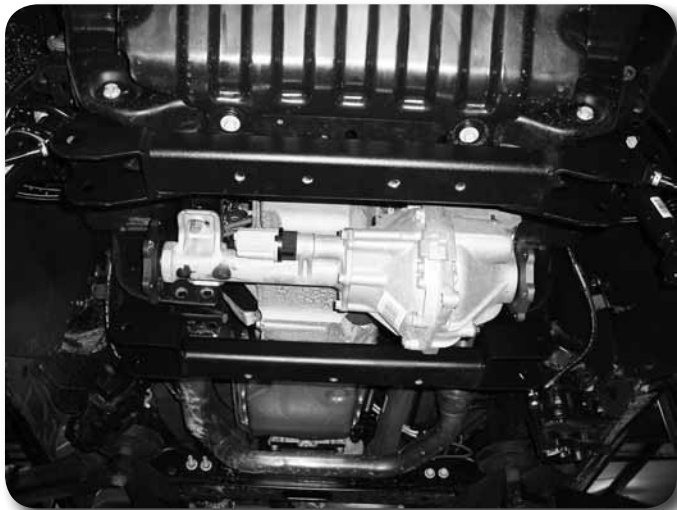

Figure 21

39. Attach the new differential skid plate to the front and rear crossmembers with $\frac{1}{2}$ " x 1-1/4" bolts and $\frac{1}{2}$ " SAE washers. The skid plate mounts to the rear crossmember with one bolt and washer **Figure 22**. The skid plate mounts to the front crossmember with two bolts and washers. Use Loctite on all skid plate bolts. Leave hardware loose.

Step 35 Note

The breather line may need to be accessed through the engine compartment to be rerouted for more slack.

Step 39, 40 Note

Hardware for the differential skid plate and crossmember support strut is located in hardware pack #643.

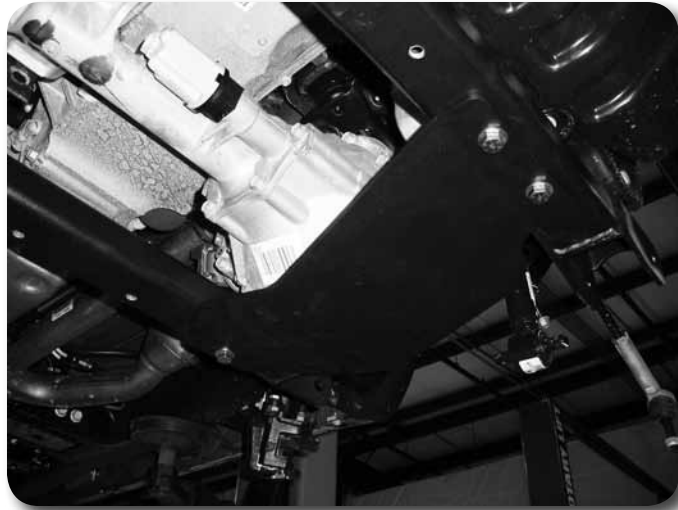

Figure 22

40. Attach the provided crossmember support strut to the front and rear crossmembers with 1/2" x 1-1/4" bolts and 1/2" SAE washers. The ends of the support strut are bent to set flush with the bottoms of the crossmembers **Figure 23**. Use Loctite on the support bolts. Leave hardware loose.

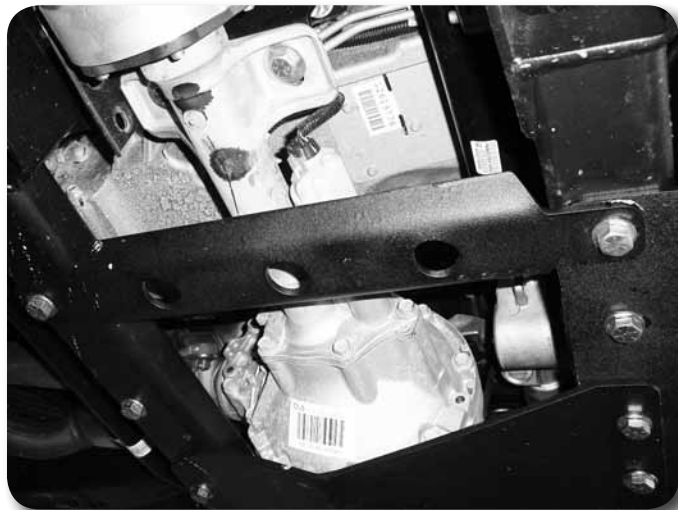

Figure 23

Step 41 Note

Hardware for the lower control arms is located in hardware pack #621.

41. Install the OE lower control arms in the new crossmembers and fasten with 5/8" x 4-1/2" (front) and 5/8" x 5-1/2" (rear) bolts, nuts and 5/8" SAE washers. Run the bolts from front to rear. Leave hardware loose.
42. With the crossmembers, control arms, skid plate and support strut installed, go back and torque the crossmember mounting bolts to 125 ft-lbs and the skid plate/support strut hardware to 65 ft-lbs.
43. Locate the factory strut assemblies that were removed earlier. Place indexing marks on the strut body, strut cap and upper coil seat for reference when the new strut is reassembled.

Caution: Coil spring is under extreme pressure. Improper removal/installation of coil spring could result in serious injury or death. Use only a high-quality spring compressor and carefully read and follow the manufacturer's instructions.

44. Using an appropriate strut compressor, compress the coil spring and remove the upper strut nut. Remove the strut from the coil spring.

45. Remove the factory bump stop from the factory strut rod and install it on the new provided strut. Apply grease to the ID of the bump stop to ease installation.
46. Install the new strut, orienting it the same as the factory one, in the coil spring. Fasten the strut with the new provided nut. Pay close attention to the lower mounting bar pin as it is not angled perpendicular to the strut body. This bar pin must be oriented correctly to mate to the lower control arm properly **Figure 24**. Torque the strut nut to 35 ft-lbs.



Figure 24

Step 46 Note

The new strut cylinders are shipped collapsed. Rotate the strut rod counter-clockwise to allow it to extend

47. Locate the two captive nuts on the factory strut bar pin. Carefully remove these nuts and transfer them to the new strut.
48. Install the new strut assembly to the appropriate frame mount with the original nuts. Leave hardware loose.
49. Swing the lower control arm up to the strut and fasten it with the original mounting bolts. Torque lower and upper strut hardware to 40 ft-lbs.
50. Remove the hub bearing/rotor assembly and brake dust shield from the factory steering knuckles. Be sure to note which hub goes on which side of the vehicle. Save mounting bolts.
51. The brake dust shield needs to be trimmed. Measure in from the lower vertical edge (opposite the ABS sensor location) $\frac{3}{4}$ " and make a vertical cut line along the entire flat section **Figure 25**. Cut the mark section off of the brake dust shield.

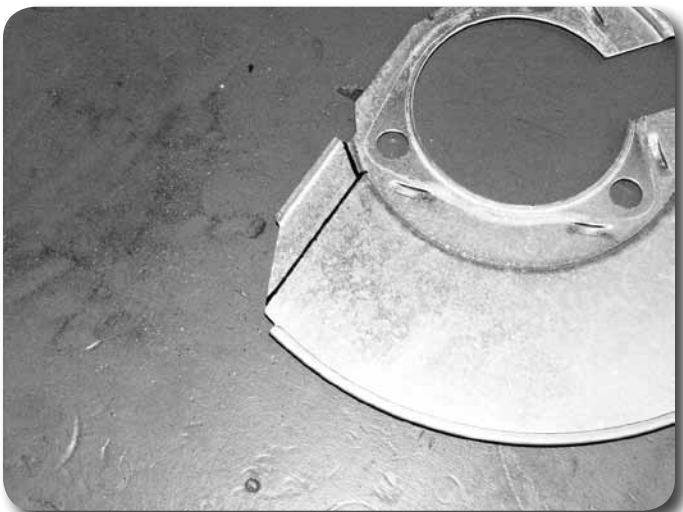

Figure 25

Step 48, 49 Notes

Be sure the strut is oriented properly in the vehicle. When attached to the lower control arm the bar pin should be relatively flush to the lower control arm mounting surface.

52. Install the modified dust shield and hub/rotor in the corresponding new knuckles. Fasten the hub/shield with the OE bolts. Apply Loctite to the bolt threads and torque to 133 ft-lbs. Be sure that the ABS line is run properly through the dust shield and out above the steering arm on the knuckle.

Step 53 Note

To make connecting the upper ball joint easier, loosen the upper control arm cam bolts at the frame and rotate the cams to shift the control arm outward.

53. Install the assembled knuckle on the lower control arm with the original lower ball joint nut. Attach the knuckle to the upper control arm with the original upper ball joint nut. Torque the upper ball joint nut to 37 ft-lbs and the lower ball joint nut to 74 ft-lbs **Figure 26**.



Figure 26

54. Install the factory CV axle shaft into the hub and fasten with the original nut/washer and torque to 155 ft-lbs. Install dust cap.
55. Position the provided CV spacer between the CV shaft and the differential mounting flange **Figure 27**. Fasten the CV and spacer to the differential flange with 10mm x 70mm bolts and 10mm washers. Use Loctite on the bolt threads and torque to 45 ft-lbs using a crossing pattern.

Step 55 Note

Hardware for the CV spacers is located in hardware pack #644.

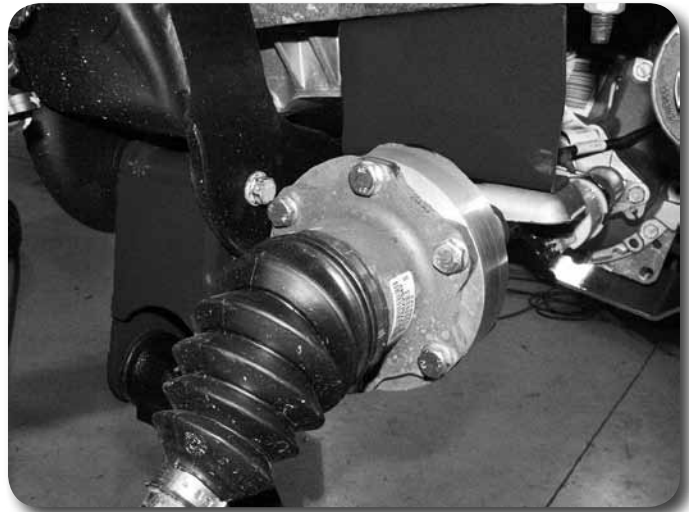

Figure 27

56. Working on one side at a time, remove the tie rod end from the steering link **Figure 28A**. Trim 3/8" off of both the tie rod end and the steering link **Figure 28B,C**. This will allow for proper alignment adjustment once the kit is complete. Once the two pieces are trimmed, clean the ends of the threads and reinstall the tie rod end on the steering link. Repeat on other side of the vehicle.



Figure 28A

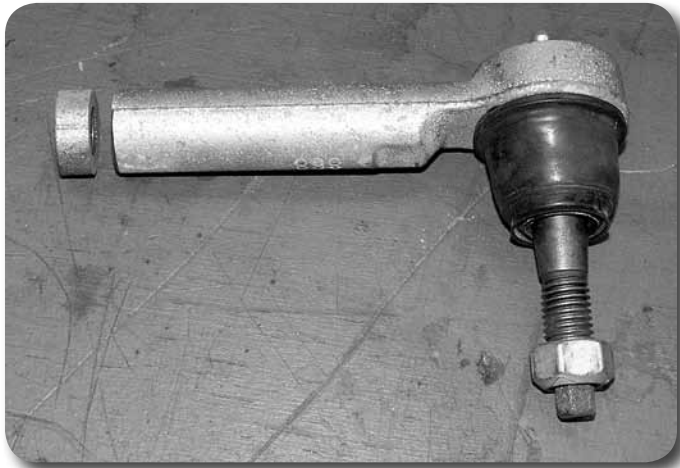

Figure 28B



Figure 28C

Step 59 Note

It may be easier to remove the brake line from the bracket by removing it from the vehicle completely and holding the bracket in a bench vise.

57. 56 Disconnect the factory rubber brake line from the hard line at the frame. Remove the retaining clip and remove the brake line from the bracket. Disconnect the bracket from the frame. Save hardware.
58. Attach the caliper to the new steering knuckle with the original mounting hardware. Torque bolts to 125 ft-lbs.
59. Carefully remove the metal retainer bracket from the factory rubber brake line.
60. Locate the threaded hole where the factory brake line bracket mounted. Measure out 1-3/8" on the upper control arm mount and mark. Drill a 5/16" hole at the mark **Figure 29**.



Figure 29

Step 61 Note

Hardware for the brake line brackets is located in hardware pack #643.

61. Attach the provided brake line bracket to the upper control arm mount using the original mounting hole/hardware and the newly drilled hole/provided 5/16" x 3/4" bolt, nut, and washers. **Figure 30** Leave hardware loose.

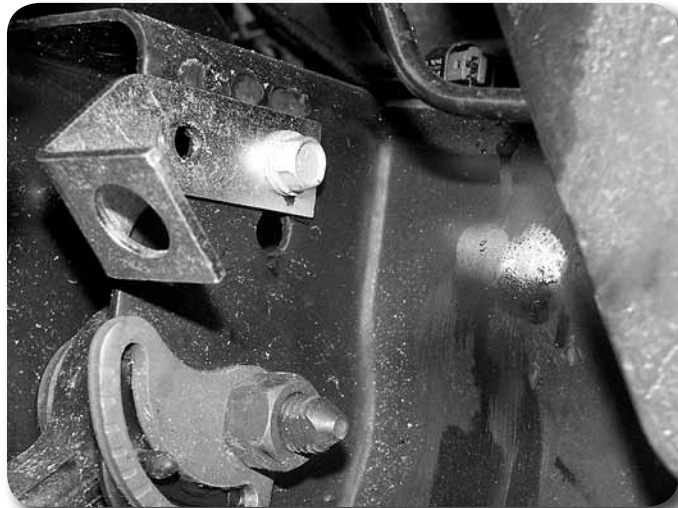

Figure 30

62. Carefully reform the brake hard line down near the new bracket. Run the end of the rubber brake hose through the bracket and attach it to the hard line. Tighten the fitting securely. Retain the brake line to the bracket with the original clip.
63. With the brake line installed go back and torque the new brake line bracket to 20 ft-lbs.

64. 63. Attach the ABS line to the upper control arm with the original brake line mounting bolt and provided wire clamp **Figure 31**.

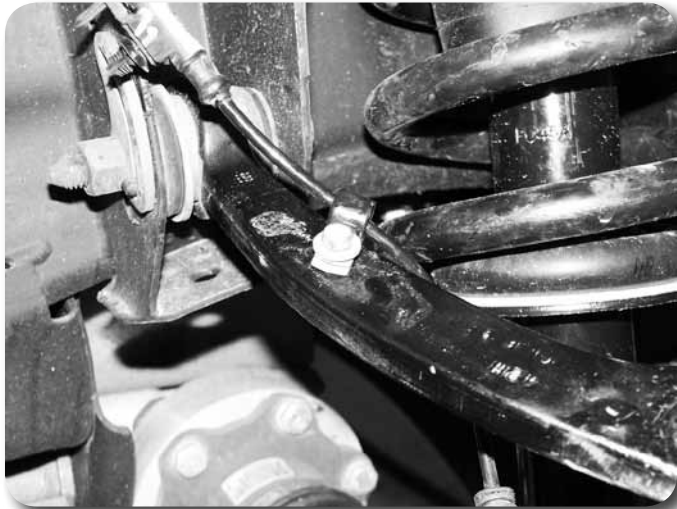

Figure 31

65. Reconnect ABS line at the frame. Attach the ABS line to the steering knuckle with the provided wire clamps and $\frac{1}{4}$ " x $\frac{3}{4}$ " bolt, flat washer and lock washer. Torque bolt to 15 ft-lbs. Use zip ties to retain the remaining section of the ABS line as needed to keep it away from rotating objects **Figure 32**.



Figure 32

Step 65 Note
Hardware for the brake line clamps is located in hardware pack #643.

66. Locate the original sway bar link mounting hole on the lower control arm. Measure inward from the center on the hole 1-1/2" (toward the frame mount) and mark. Measure in from the back edge of the control near the first mark $\frac{3}{4}$ " and mark. Where the two marks cross drill a $\frac{5}{8}$ " hole **Figure 33**.

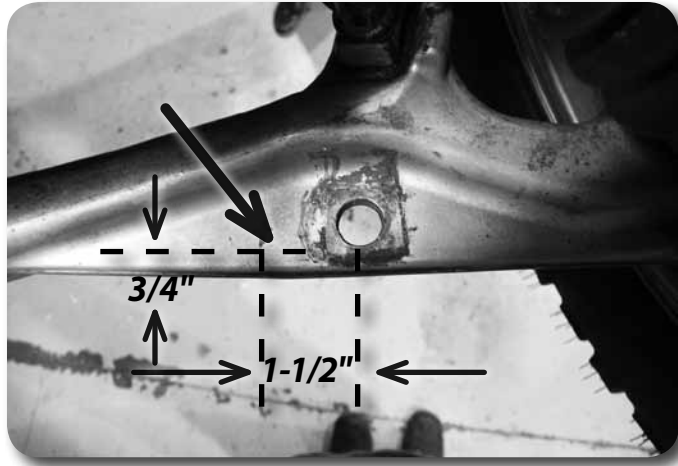

Figure 33

Step 67 Note

Hardware for the sway bar drops is located in hardware pack #643.

67. Attach the factory front sway bar to the original mounts in conjunction with the provided drop brackets and 10mm x 130mm bolts/washers. Use Loctite on the bolt threads and torque to 45 ft-lbs Figure 34.



Figure 34

68. Attach the original sway bar links and hardware to the sway bar end and new hole in the lower control arm Figure 35. Tighten the sway bar link until the bushings begin to swell.



Figure 35

69. Install the wheels/tires and lower the front of the vehicle to the ground. Torque lug nuts to 140 ft-lbs.
70. Bounce the front of the vehicle to settle the suspension. Torque the lower control arm mounting bolts to 150 ft-lbs. If the upper control arm cam bolts were loosened during the installation, center the cams and torque the bolts to 125 ft-lbs.
71. Check all hardware for proper torque.
72. Bleed the entire brake system. See service manual for proper brake system bleeding procedures.
73. Reconnect the battery cables to the battery.

» REAR INSTALLATION

1. Block the front wheels for safety.
2. Disconnect the track bar from the rear axle mount. Save mounting hardware. **Figure 36**
3. Raise the rear of the vehicle and support with jack stands under the frame rails just ahead of the lower control arm mounts.
4. Support the axle with a hydraulic jack.
5. Remove the wheels.
6. Disconnect the ABS wire from retainer clip at the axle. Remove the factory shocks and sway bar links. Save all mounting hardware. **Figure 36**



Figure 36

7. Disconnect the brake line junction block from the bracket mounted to the differential. Figure 37



Figure 37

8. Disconnect the parking brake cable loop from the driver's side axle lower control arm mount. Figure 38



Figure 38

9. Disconnect the parking brake cable loop from the passenger's side frame rail. Remove the loop from the cable. **Figure 39**



Figure 39

10. Remove the parking bracket cable from the retaining clips holding it to the rear track bar. **Figures 37, 39**
11. Loosen but do not remove the four (two per arm) lower control arm pivot bolts.
12. Lower the rear axle until the springs can be pulled free. Remove the springs. Save the top and bottom rubber isolators.
13. Ensure the axle is well supported. Working on one side of the vehicle at a time, remove rear upper control arms. Adjust length of new rear upper control arms to 17-3/4". Install arms with new bushings sleeves 3/4" O.D. x 2" long, and factory hardware. Do not tighten hardware at this time. **Figure 40**

Step 12 Note
Take care not to over-extend the brake lines and ABS wires..

Step 13 Note
The 17-3/4" measurement is a preliminary measurement that may require adjusting to eliminate possible driveline vibration.

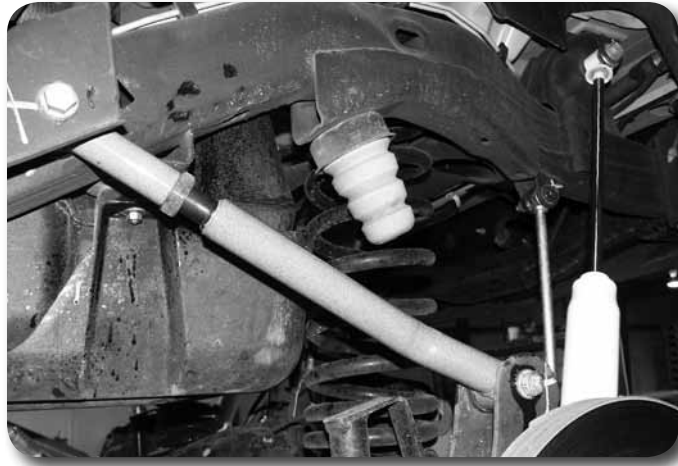

Figure 40

14. With axle still supported remove the lower control arm-to-axle pivot bolts and swing the lower control arms down away from the axle.
15. Mark and cut the small tab protruding out on the top front end of the lower control arm mounts so that a single straight edge is left. Figure 41

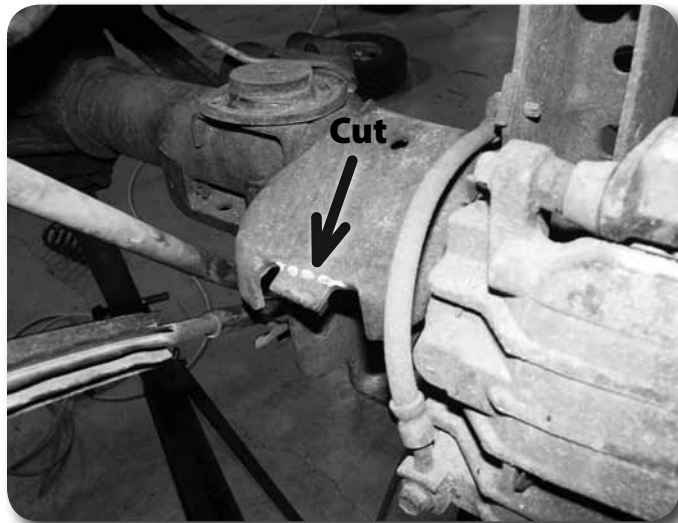

Figure 41

Step 16 Note

The 7/16" hardware is located in bolt pack 551.

16. Loosely mount the provided bump stop brackets on the top of the lower control arm axle mount using the existing hole Figure 41 and 7/16" hardware from bolt pack. The longer end of the mounting plate will go to the front of the vehicle Figure 42.



Figure 42

17. With the bump stop brackets in position, using the bracket as a template, mark the other mounting hole to be drilled in the axle mount.
18. Rotate the brackets out of the way and drill 7/16" holes at the marks. Attach the brackets with the remaining 7/16" hardware, the front bolts run from the bottom up, and torque all four mounting bolts to 50 ft-lbs.
19. Install the new coil spring in conjunction with the factory upper and lower rubber isolators.
20. Raise the axle to engage the springs enough to allow for the lower control arms to be reattached. Reattach the lower control arms with the factory hardware. Leave hardware loose.
21. Loosely install the provided track bar relocation bracket to the axle with a 9/16" x 3-1/2" bolt, nut and 9/16" SAE washers through the original track bar mounting hole. **Figure 43**

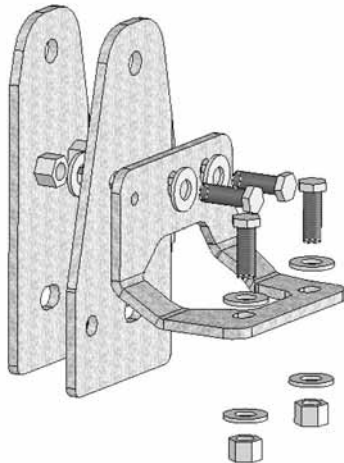

Figure 43

22. Ensure that the track bar bracket is square to the bottom of the factory bracket and mark the hole in the back of the bracket that best matches the axle bracket to be drilled. Remove the bracket and drill 1/2" hole. **Figure 44**

Step 19 Note

Take care not to over-extend the brake lines.

Step 21 Note

The 9/16" hardware is located in bolt pack 565.



Figure 44

Step 23 Note

The 1/2" & 3/8" hardware is located in bolt pack 565..

Step 26 Note

The 12mm hardware is located in bolt pack 551.

23. Reinstall the track bar bracket with the 9/16" hardware in conjunction with the provided 7/8" spacer sleeve. Attach to axle bracket with new 1/2" x 1-1/4" bolt. Leave loose.
24. Attach the support bracket through the two factory slots on top of the axle with 3/8" x 1-1/4" bolts, nuts and SAE flat washers. Leave loose.
25. Tighten the track bar bracket hardware starting with the 9/16" (95 ft-lbs), then the 1/2" (65 ft-lbs), finally 3/8" (35 ft-lbs). The track bar will be reinstalled later with the weight of the vehicle on the axle.
26. Install the provided hourglass bushings and sleeves (5/8" x 1.5") in the new extended sway bar links. Install the links with the factory upper hardware and the provided 12mm x 70mm bolts, nuts and 7/16" USS flat washers at the sway bar (Fig 10). Torque hardware to 60 ft-lbs.
27. Install the new shocks with the factory hardware. Torque to 90 ft-lbs.
28. Install the provided brake line spacer sleeve (3/4") between the brake line junction block and the differential mounting tab and fasten with the provided 8mm x 100mm bolt and 5/16" washer. **Figure 45** Torque to 15 ft-lbs.



Figure 45

29. Reattach the parking brake cable to the driver's side axle mount with the original hardware.

30. Attach the emergency brake cable to the mounting bolt at the top of the differential with a new cable clamp. Torque to 20 ft-lbs. Ensure that the cable is routed so that it does not rub on any suspension components. Use the provided plastic wire ties where necessary.
31. Attach ABS wires to the inside of the fender well or frame rail with provided cable clamps and #12 sheet metal screws. Ensure that cables will not be overextended. Use provided plastic ties to retain the cables if necessary. Return ABS wires to retaining clips on axle. It may be necessary to slide the rubber protective grommet down on the ABS wire. Spray some lubricant around the grommet to aid in movement.
32. Install wheels and lower vehicle to ground. Bounce the vehicle to settle the suspension.
33. Torque the lower control arm mounting bolts to 95 ft-lbs.
34. Install the track bar in the track bar relocation bracket with the factory hardware. Torque to 90 ft-lbs.
35. Check all hardware for proper torque.
36. Check all hardware after 500 miles.

Recommend Alignment Specifications

CASTER

$3.30^{\circ} \pm 1.00^{\circ}$

CAMBER

$-0.10^{\circ} \pm 0.60^{\circ}$

TOE

$+0.10^{\circ} \pm 0.20^{\circ}$

» POST INSTALLATION

1. Double check all fasteners for proper torque.
2. Check all moving parts for clearance.
3. Complete a full radius turning check to ensure that no interference occurs.
4. Align headlights
5. Double check the brake lines for adequate slack at full wheel travel.
6. Complete a vehicle alignment.
7. Check all fasteners after 500 miles.

Post-Installation Warnings

1. Check all fasteners for proper torque. Check to ensure for adequate clearance between all rotating, mobile, fixed, and heated members. Verify clearance between exhaust and brake lines, fuel lines, fuel tank, floor boards and wiring harness. Check steering gear for clearance. Test and inspect brake system.
2. Perform steering sweep to ensure front brake hoses have adequate slack and do not contact any rotating, mobile or heated members. Inspect rear brake hoses at full extension for adequate slack. Failure to perform hose check/ replacement may result in component failure.
3. Perform head light check and adjustment.
4. Re-torque all fasteners after 500 miles. Always inspect fasteners and components during routine servicing.

