



INSTALLATION INSTRUCTIONS

PART# BGGRG15HDS

GRILLE GUARD: GMC 2500HD/3500HD 2015-UP WITH SENSORS

NOTE: Work on one side at a time so the bumper does not move during installation

1. Start with the driver's side. Remove the side and bottom tow hook bolts.
2. Remove the tow hook. Slide the formed side of the mounting bracket through the tow hook opening. The mounting bracket will be installed to the outside of the frame. Place the side of the tow hook into the provided slot in the lower mounting bracket. Reinstall the tow hook to its original position. Make sure the bolt goes through the lower mounting bracket, frame and tow hook. Use the 2 factory bolts to mount the mounting bracket to the frame per side.
3. Follow the same steps for passenger side.
4. Open the hood and remove the plastic radiator cover. There will be (12) plastic clips.
5. Remove the (4) 10mm bolts holding the grille in place. Carefully pry grille away from its position (10) snap clips.
6. Remove the top 2 inner 15 mm bumper bolts. Do one side at a time. Mount the top bracket, with two bends, over the hole and reinstall the bumper bolt. The smaller slotted hole gets mounted to the back side of the factory bumper. The top bracket will angle outward to the side of the vehicle. Do the same for the other side.
7. Mount the grille guard to the bottom and top brackets. Use the ½" carriage bolts to install. If the brackets are a little wide, you can push them in when you get ready to slide the grille guard over the brackets.
8. Level the grille guard and then tighten carriage bolts.
9. Tighten all the bolts and then reinstall the grille and plastic radiator cover.

MAKE SURE ALL NUTS AND BOLTS ARE TIGHT!

Special care should be exercised in the handling, storage and installation of Roughneck HD equipment. The actual weight of each piece of equipment will vary depending on style and model. The weight of the equipment is sufficient in volume to warrant special care, assistance and in some instances the use of mechanical equipment during the transfer and installation of the equipment. Do not assume a position directly under the equipment during installation. Be sure the equipment has been connected and stabilized during installation to prevent falling or shifting of positions. Periodically check tightness of bolts to make sure they are tight and unlikely to fail.

BGGRG15HDS

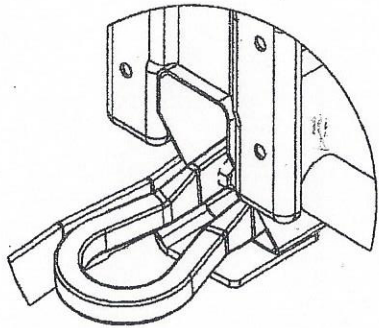

DETAIL A
SCALE 1:6

PART #	DESCRIPTION	QUANTITY
1	TOP MOUNTING BRACKET - P	1
2	TOP MOUNTING BRACKET - D	1
3	MOUNTING BRACKET DRIVER	1
4	MOUNTING BRACKET PASSENGER	1
5	SPACER	2
6	TOP BUMPER BRACKET	2
7	BLACK CARRIAGE BOLT 1/2" - 13 X 1 1/2"	6
8	1/2" BLACK FLAT WASHER	6
9	HEX HEAD BOLT 1/2" - 13 X 1 3/4"	2
10	LOCK WASHER 1/2"	2
11	BLACK LOCK NUT 1/2"	6
12	FLAT WASHER 1/2"	4
13	HEX NUT 1/2" - 13	2

