

# INSTALLATION GUIDE

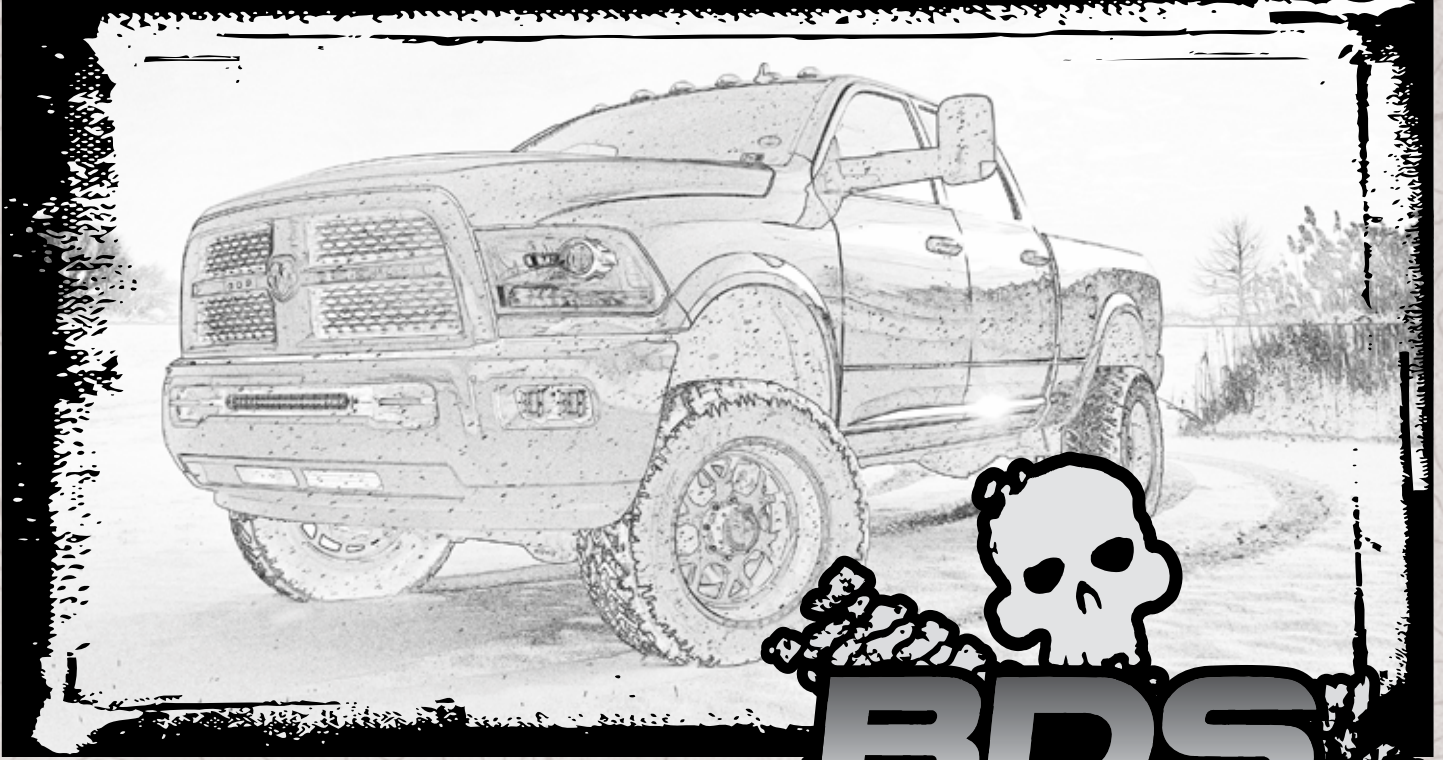

Part#: 012311

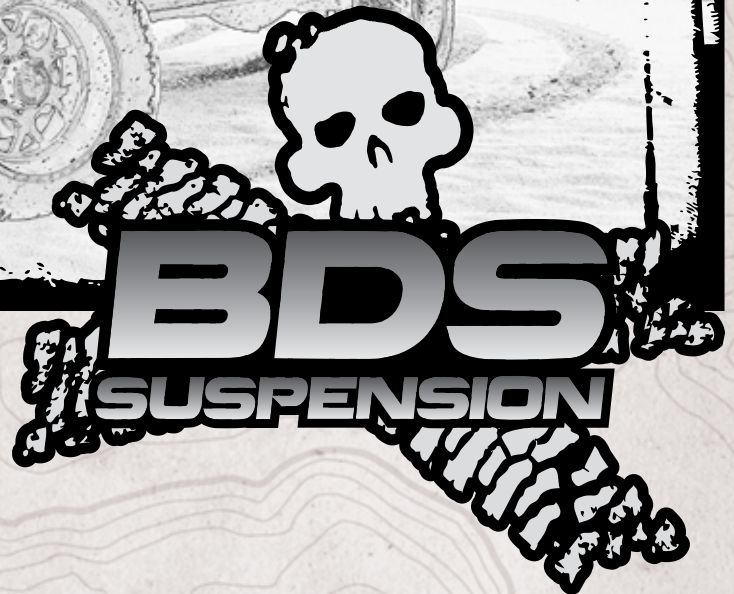

**HARDCORE LIMITED LIFETIME WARRANTY**

## 3" Suspension System

Dodge Ram 3500 | 2013

Dodge Ram 2500 | 2014

Rev. 041917

491 W. Garfield Ave., Coldwater, MI 49036 • Phone: 517-279-2135

E-mail: [tech-bds@sporttruckusainc.com](mailto:tech-bds@sporttruckusainc.com)

# Read And Understand All Instructions And Warnings Prior To Installation Of System And Operation Of Vehicle.



## THANK YOU

Your truck is about to be fitted with the best suspension system on the market today. That means you will be driving the baddest looking truck in the neighborhood, and you'll have the warranty to ensure that it stays that way for years to come.

Thank you for choosing BDS Suspension!

### BEFORE YOU START

BDS Suspension Co. recommends this system be installed by a professional technician. In addition to these instructions, professional knowledge of disassembly/ reassembly procedures and post installation checks must be known.

### FOR YOUR SAFETY

Certain BDS Suspension products are intended to improve off-road performance. Modifying your vehicle for off-road use may result in the vehicle handling differently than a factory equipped vehicle. Extreme care must be used to prevent loss of control or vehicle rollover. Failure to drive your modified vehicle safely may result in serious injury or death. BDS Suspension Co. does not recommend the combined use of suspension lifts, body lifts, or other lifting devices. You should never operate your modified vehicle under the influence of alcohol or drugs. Always drive your modified vehicle at reduced speeds to ensure your ability to control your vehicle under all driving conditions. Always wear your seat belt.

### BEFORE INSTALLATION

- Special literature required: OE Service Manual for model/year of vehicle. Refer to manual for proper disassembly/reassembly procedures of OE and related components.
- Adhere to recommendations when replacement fasteners, retainers and keepers are called out in the OE manual.
- Larger rim and tire combinations may increase leverage on suspension, steering, and related components. When selecting combinations larger than OE, consider the additional stress you could be inducing on the OE and related components.
- Post suspension system vehicles may experience drive line vibrations. Angles may require tuning, slider on shaft may require replacement, shafts may need to be lengthened or trued, and U-joints may need to be replaced.
- Secure and properly block vehicle prior to installation of BDS Suspension components. Always wear safety glasses when using power tools.
- If installation is to be performed without a hoist, BDS Suspension Co. recommends rear alterations first.
- Due to payload options and initial ride height variances, the amount of lift is a base figure. Final ride height dimensions may vary in accordance to original vehicle attitude. Always measure the attitude prior to beginning installation.



Visit [560plus.com](http://560plus.com) for more information.

### TIRES AND WHEELS

35x12.50x17 / 18 / 20  
9" Wide Wheel With 4-1/2" ~ 5" Backspacing



### BEFORE YOU DRIVE

Check all fasteners for proper torque. Check to ensure for adequate clearance between all rotating, mobile, fixed, and heated members. Verify clearance between exhaust and brake lines, fuel lines, fuel tank, floor boards and wiring harness. Check steering gear for clearance. Test and inspect brake system.

Perform steering sweep to ensure front brake hoses have adequate slack and do not contact any rotating, mobile or heated members. Inspect rear brake hoses at full extension for adequate slack. Failure to perform hose check/ replacement may result in component failure. Longer replacement hoses, if needed can be purchased from a local parts supplier.

Perform head light check and adjustment.

Re-torque all fasteners after 500 miles. Always inspect fasteners and components during routine servicing.

# CONTENTS OF YOUR KIT

BDS012311 Main Box Kit		
Part #	Qty	Description
02475	2	Brake Line Bracket
B561G2	2	5/16"-18 x 1" Self Threading Bolt
02378BK	2	Bump Stops
A197	(1)	Adjustable Track Bar
02240	1	Adjustable T-bar (Axle End)
02241	1	Adjustable T-bar (Frame End)
02738	1	Adjustable T-bar (Turnbuckle)
B56X114G8	4	5/16" x 1-1/4" SHCS
B1043	(1)	Bag Kit (Track Bar)
3565BK	4	Dodge T-bar Bushings
143	2	2013 Dodge T-bar Sleeve
342701	1	Loc-tite
A239	(2)	Sway Bar Link Assembly
911120	2	Sway Bar Link
M00475-BK-01	4	Bushing
7608	4	Grease Zerk
03012	2	Clevis
03029	2	Sleeve - Upper
149	2	Sleeve - Lower
M03212-BK-01	2	Offset Spacer
677	1	Bolt Pack

BDS012231 Radius Arm Box Kit		
Part #	Qty	Description
A243	1	Radius Arm Assembly - DRV
02804	1	Dodge Radius Arm
02802	1	Aluminum Logo Plate - In DRV Position
97525A430	2	Rivet
868190	1	Rubber Bushing
A244	1	Radius Arm Assembly - Pass
02804	1	Dodge Radius Arm
02802	1	Aluminum Logo Plate - In DRV Position
97525A430	2	Rivet
868190	1	Rubber Bushing

BDS032302 3" Coil Box Kit		
Part #	Qty	Description
032302R	2	Diesel 3" Coil Spring

\*Rear Box kits - See Separate Instruction Sheets\*

## TECH TIPS

### TROUBLESHOOTING INFORMATION FOR YOUR VEHICLE

1. 3500 models with top mounted overloads that wish to retain stock load carrying capacity will need to order the 2" rear block kit (do not order dual add-a-leaf). If carrying capacity is to be reduced to that of a single rear tire vehicle without overloads, either kit can be installed - the overloads will not fit back on with the centerpin provided in the dual add-a-leaf kit.

## INSTALLATION INSTRUCTIONS

### INSTALLATION INSTRUCTIONS

1. Park vehicle on clean, flat, and level surface. Block the rear wheels for safety.
2. Disconnect the front trackbar bolt from the frame while the vehicle is still on the ground. Retain bolt and nut tab. (Fig 1a, 1b)

**FIG 1A**



### SPECIAL TOOLS

1-1/16" or 27mm Socket

**FIG 1B**



3. Raise the front of the vehicle and support the frame rails with jackstands. Note: The radius arms will be removed during this installation; do not support the weight of the truck on the radius arms.
4. Remove the wheels.
5. Remove the trackbar bolt from the axle, retain bolt and nut tab. (Fig 2)

**FIG 2**



6. Remove the factory sway bar links, they will not be reinstalled. (Fig 3)

**FIG 3**



7. Disconnect the brake line bracket from the top of the axle. Remove the brake line from the retaining clip; new brackets will be installed later. Retain hardware and clip (Fig 4a, 4b)

**FIGURE 4A**



**FIGURE 4B**



8. Disconnect the brake line from the backside of the axle. Retain hardware (Fig 5)

**FIG 5**



9. It is recommended to disconnect the drag link from the pitman arm at this time. This will prevent the joint from binding while installing new coils. Use care not to damage the drag link joint boot. (Fig 6)

**FIG 6**



10. Detach the ABS and Central Axle Disconnect wires from retaining clips to allow for extra slack when new coils will be installed.
11. Support the front axle with a hydraulic jack.
12. Disconnect the shock hardware at lower and upper mounts; keep the lower bolt and nut tab. Remove the shocks. (Fig 7)

**FIG 7**



13. Lower the axle and remove the factory coils. Use care not to overextend any brake line, ABS, or CAD wires.

## **RADIUS ARM INSTALLATION:**

14. Working on one side of the vehicle at a time, remove the factory radius arm. Retain all hardware.
15. Replace the radius arm with the new one. The 'BDS' logo will face out towards the wheel. Reattach with factory hardware. Note: Due to increased caster built into the arms, it may not be possible to reinstall the factory hardware with the opposite side hardware in. Remove one of the opposing bolts at the axle to allow the axle to rotate. (Fig 8a, 8b)

**FIG 8A**



**FIG 8B**



16. Repeat radius arm installation on opposite side.
17. Tighten the upper bolt at the axle to 180 ft-lbs. Center the lower cams and tighten to 180 ft-lbs. Do not tighten the pivot bushing hardware at the frame at this time.

### **BUMP STOP INSTALLATION:**

18. Remove the factory bump stops. It is easiest to hit them from the side with a hammer to get them to pop out. (Fig 9a)
19. Lightly grease and install new bump stops by compressing the axle and pressing the bump stops into position. (Fig 9b)

**FIG 9A**



**FIG 9B**



### **COIL / SHOCK INSTALLATION:**

20. Cut out the template at the end of the instruction sheet and place it on the PASSENGER'S side upper coil bucket at this time. Mark the center of the hole to be drilled, remove template, and drill hole to 1/2". This step is only required on the passenger's side, do not do this on the driver's side. (Fig 10a, 10b)

**FIG 10A**

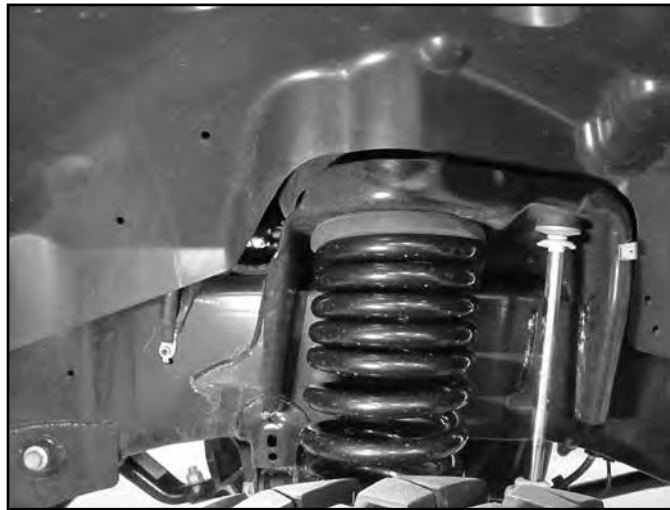

**FIG 10B**



21. Install new coils with the factory isolator on top of the coil. The end of the spring with the windings closer together will go at the top, do not install upside down. Use hydraulic jack to raise the axle to seat the coils. Ensure that the coils are seated properly. Driver's side – Figure 11, Passenger's side Figure 12a, 12b.

**FIG 11 - DRIVER'S SIDE**



**FIG 12A PASSENGER'S SIDE - CORRECT**

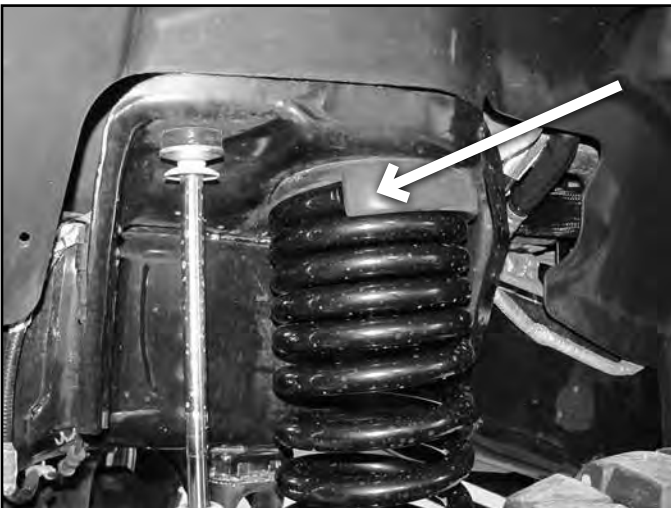

**FIG 12B PASSENGER'S SIDE - INCORRECT**



*Picture taken directly from the side.*

*Needs to be rotated 45 degrees. Picture taken from the side-front.*



22. Grease and install bushings into new shocks. Install new shocks on vehicle with factory lower hardware and new cup washers, bushings, and nut on the top. Tighten the upper nut until the bushings begin to swell, do not over tighten. Note: It is easiest to install the lower hardware first, compress the shock and allow it to expand up into the upper mounting position. Ensure that the upper mount is centered in the factory hole. Tighten lower mount to 55 ft-lbs.
23. Lower the axle and allow the axle to hang from the shocks.

## TRACKBAR INSTALLATION:

24. Fox Shocks Installation only: Fox shocks give increased droop, the axle pocket for the trackbar will need to be clearanced. Lightly remove approximately 1/8" of material from the end of the factory bracket. (Fig 13)

**FIG 13**

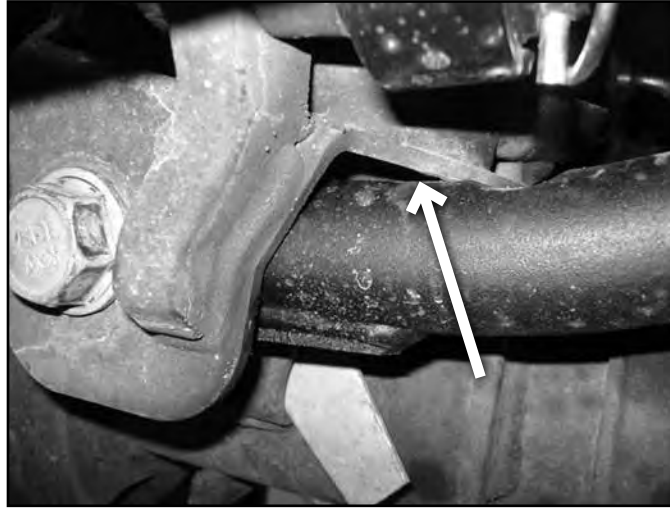

25. Grease and install bushings and sleeves into the trackbar assembly. Adjust length to 39-1/8". Remove the bolts on the adjusting collar and loc-tite threads. Tighten to 35 ft-lbs, or until the trackbar assembly is unable to be rotated.
26. Install into the vehicle by attaching the axle end first with factory bolt and nut tab. Do not tighten at this time; do not attach the frame mount at this time.
27. Swing the trackbar up to the frame mount and check for bar to factory bracket clearance. The factory brackets have a lot of variation and may need to be clearanced. Lightly grind the edge at 45 degrees to create clearance. Coat any raw material with paint. (Fig 14)

**FIG 14**



28. Reattach the factory drag link to the pitman arm with factory nut. Tighten to 65 ft-lbs.

## BRAKE LINE BRACKET:

29. Attach brake line relocation brackets to the top side of the axle with the factory bolt and 5/16" self threading bolt into the original locating tab hole. The brake lines will need to have the fittings loosened so they can be rotated and pointed up. Attach the brake line to the bracket with retaining clip. The brackets will need to be offset in towards the 'inside' of the vehicle to give more clearance to the larger body of the shock. It will be necessary to slightly reform the hard line. Note: If any brake fluid is lost, the system must be bled at the end of the installation. (Fig 15a, 15b)

**FIG 15A**



**FIG 15B**

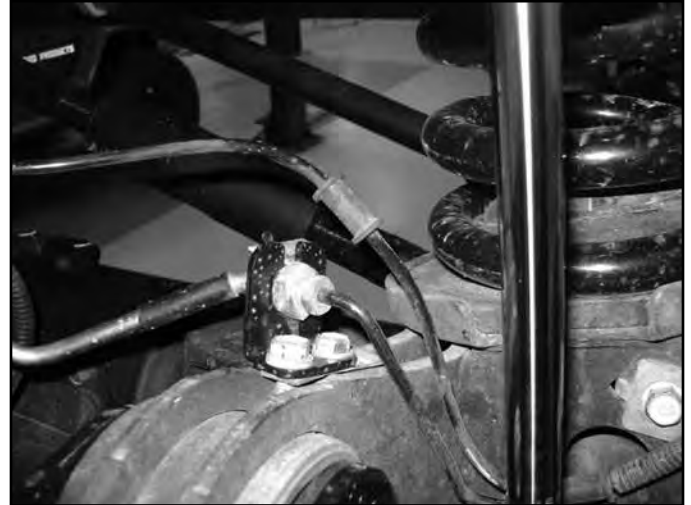

30. Reattach the brake line to the back side of the axle with factory bolt, tighten to 15 ft-lbs.

## SWAY BAR LINKS:

31. Install new sway bar links. The clevis bracket will be a tight squeeze to get over the factory sway bar (keeps it from rotating). It may be necessary to slightly clear the widest part of the sway bar to get the bracket to fit over it. Attach with hardware as shown. (Fig 16a, 16b, 16c, & 16d)

**FIG 16A**

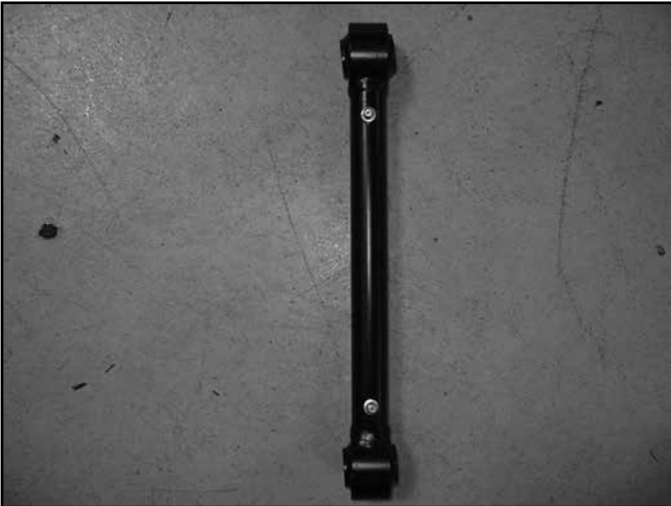

**FIG 16B**



**FIG 16C**



**FIG 16D**

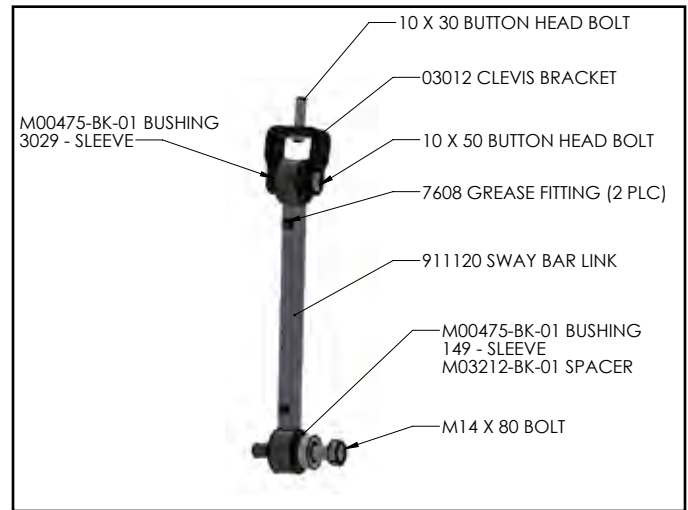

- 32. Reinstall wheels, lower vehicle to the ground and torque lug nuts to specification.
- 33. Tighten the radius arm mount at the frame to 180 ft-lbs.
- 34. Have an assistant turn the steering wheel to help align the trackbar into the frame mounting bracket. Attach with factory bolt and nut tab. Tighten the axle mount to 285 ft-lbs and the frame mount to 324 ft-lbs.
- 35. Straighten the steering wheel by adjusting the drag link adjuster. Do not drive the vehicle for extended periods of time with the steering wheel off center.

**REAR KIT (3500 TRUCKS ONLY - 2500 SEE SEPARATE INSTRUCTION SHEET):**

- 36. Raise the rear of the vehicle, block the front wheels for safety. Support the frame rails with jackstands.
- 37. Disconnect e-brake cable and reroute the line to give adequate slack in the cable at full droop, reattach once routed for extra slack. (Fig. 21A, 21B)

**FIGURE 21A**

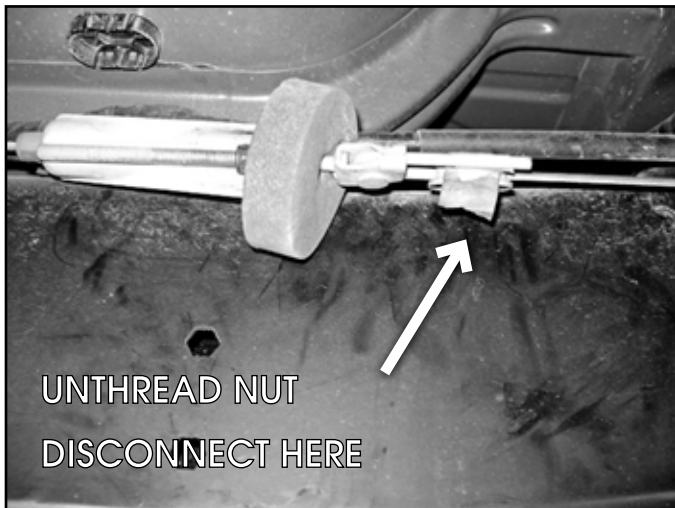

**FIGURE 21B**



- 38. Remove the factory shocks, retain all mounting hardware.
- 39. Support the rear axle with a hydraulic jack. Remove the u-bolts and plates from one side of the vehicle only. Loosen the u-bolts, but do not remove the opposite side.

**2" REAR BLOCK INSTALLATION (DUAL ADD-A-LEAFS SKIP AHEAD):**

- 40. Lower the axle and install new 2" lift block, with the small end of the block towards the front of the vehicle. Install new u-bolts and install the nuts, but do not tighten at this time.
- 41. Repeat block and u-bolt installation on opposite side of the vehicle.
- 42. Tighten u-bolts snugly at this time, do not torque until the vehicle is on the ground.

## OPTIONAL DUAL ADD-A-LEAF INSTALLATION:

43. The installation can be performed with the leaf springs remaining installed in the truck, but extra care must be used to ensure that cables / wires are not over extended.
44. Lower the axle on the side with the u-bolts removed.
45. Trim the leaf spring clamps near where they bend over the main leaf to allow the leaves to be disassembled.
46. Clamp the leaf pack together with c-clamps, remove the dual center pins.
47. Loosen the clamps and allow the leaf pack to disassemble. Remove the lowest block off the leaf pack, remove the plastic center pin and replace it with the metal one (#01599) provided in the kit. Use a hammer, vice, or press to install the new metal pin.
48. The main leaf and the leaf, leaf with clamps, and factory overload leaf will all be reused. There will be one leaf that is not intended to be reused, however, it is possible to reinstall this leaf if the user desires.
49. Reassemble pack with new leaves with new center pins. Note: Overload applications will not reuse overloads. (Fig 24c, 24d)

**FIGURE 24C**



**FIGURE 24D**



50. Raise axle and attach with new u-bolts with factory spring plate. Snug u-bolts securely, but do not torque at this time.
51. Remove the factory bump stops and reinstall with bump stop spacers and new 10mm x 80mm hardware.
52. Grease bushings and sleeves, install them into both ends of the shocks. Install new shocks with factory hardware. Tighten to 65 ft-lbs. If installing optional Fox shocks, the body will be located at the frame mount.
53. Reinstall wheels, torque to specification. Lower vehicle to the ground and torque u-bolts to 120 ft-lbs.
54. Recheck all hardware for proper torque, check again after 500 miles, and at regularly scheduled maintenance intervals.
55. An alignment is now recommended. The caster should fall between 4.00 and 5.50 (between 5.00 and 5.50 is recommended), adjustment for better driving characteristics may be required.



### **WE WANT TO SEE YOUR RIDE!**

Grab photos of your BDS-equipped truck in action and send them in for a chance to be featured. Send it in to our Bad Ass Rides customer gallery at [bds-suspension.com/bar](http://bds-suspension.com/bar) and post them on the BDS Fan Page on Facebook at [facebook.com/BDSSuspensions](https://facebook.com/BDSSuspensions). Don't forget about your BDS swag! BDS offers t-shirts, hoodies, decals and more available on the BDS website or through your local BDS distributor.

## **TIME TO HAVE SOME FUN**

**Thank you for choosing BDS Suspension.**

For questions, technical support and warranty issues relating to this BDS Suspension product, please contact your distributor/installer before contacting BDS Suspension directly.

