

INSTALLATION GUIDE

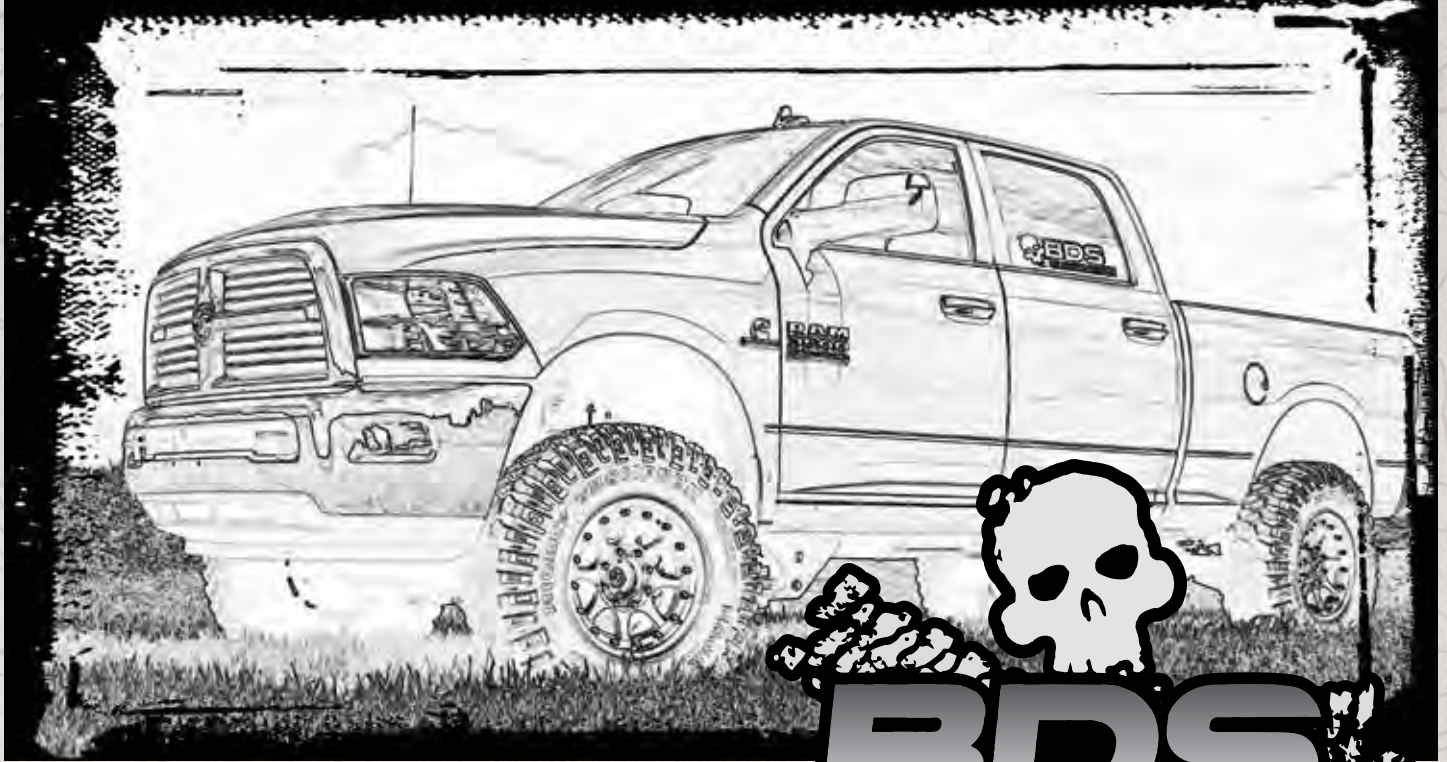

Part#: 012402

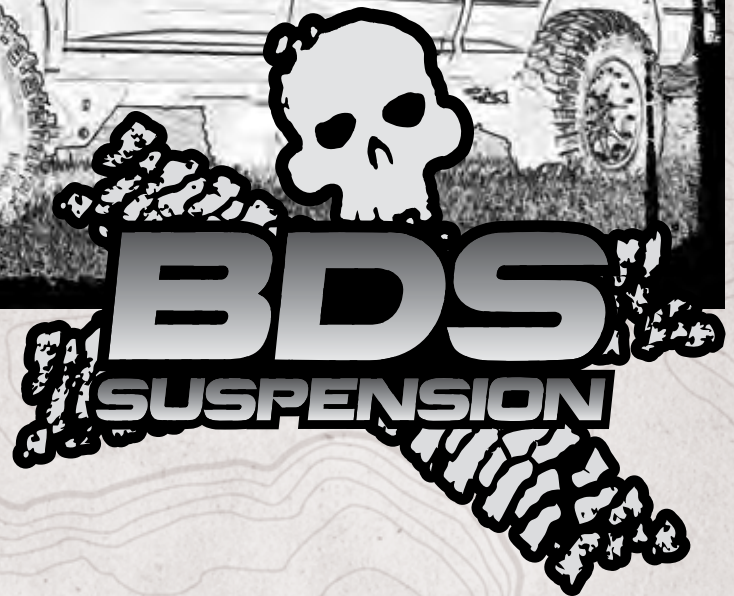

HARDCORE LIMITED LIFETIME WARRANTY

4" Radius Arm Suspension System

Dodge Ram 2500 4WD Power Wagon | 2014-18

Rev. 022620

491 W. Garfield Ave., Coldwater, MI 49036 • Phone: 517-279-2135

Web: www.bds-suspension.com • E-mail: tech-bds@ridefox.com

Read And Understand All Instructions And Warnings Prior To Installation Of System And Operation Of Vehicle.



THANK YOU

Your truck is about to be fitted with the best suspension system on the market today. That means you will be driving the baddest looking truck in the neighborhood, and you'll have the warranty to ensure that it stays that way for years to come. Thank you for choosing BDS Suspension!

BEFORE YOU START

BDS Suspension Co. recommends this system be installed by a professional technician. In addition to these instructions, professional knowledge of disassembly/ reassembly procedures and post installation checks must be known.

FOR YOUR SAFETY

Certain BDS Suspension products are intended to improve off-road performance. Modifying your vehicle for off-road use may result in the vehicle handling differently than a factory equipped vehicle. Extreme care must be used to prevent loss of control or vehicle rollover. Failure to drive your modified vehicle safely may result in serious injury or death. BDS Suspension Co. does not recommend the combined use of suspension lifts, body lifts, or other lifting devices. You should never operate your modified vehicle under the influence of alcohol or drugs. Always drive your modified vehicle at reduced speeds to ensure your ability to control your vehicle under all driving conditions. Always wear your seat belt.

BEFORE INSTALLATION

- Special literature required: OE Service Manual for model/year of vehicle. Refer to manual for proper disassembly/reassembly procedures of OE and related components.
- Adhere to recommendations when replacement fasteners, retainers and keepers are called out in the OE manual.
- Larger rim and tire combinations may increase leverage on suspension, steering, and related components. When selecting combinations larger than OE, consider the additional stress you could be inducing on the OE and related components.
- Post suspension system vehicles may experience drive line vibrations. Angles may require tuning, slider on shaft may require replacement, shafts may need to be lengthened or trued, and U-joints may need to be replaced.
- Secure and properly block vehicle prior to installation of BDS Suspension components. Always wear safety glasses when using power tools.
- If installation is to be performed without a hoist, BDS Suspension Co. recommends rear alterations first.
- Due to payload options and initial ride height variances, the amount of lift is a base figure. Final ride height dimensions may vary in accordance to original vehicle attitude. Always measure the attitude prior to beginning installation.



Visit 560plus.com for more information.

TIRES AND WHEELS

FITMENT GUIDE

4" POWER WAGON LIFT:

37x13.50 w/ 5.625" Backspacing on 9" wide wheel
37x12.50 w/ 4.5" Backspacing on 9" wide wheel



BEFORE YOU DRIVE

Check all fasteners for proper torque. Check to ensure for adequate clearance between all rotating, mobile, fixed, and heated members. Verify clearance between exhaust and brake lines, fuel lines, fuel tank, floor boards and wiring harness. Check steering gear for clearance. Test and inspect brake system.

Perform steering sweep to ensure front brake hoses have adequate slack and do not contact any rotating, mobile or heated members. Inspect rear brake hoses at full extension for adequate slack. Failure to perform hose check/ replacement may result in component failure. Longer replacement hoses, if needed can be purchased from a local parts supplier.

Perform head light check and adjustment.

Re-torque all fasteners after 500 miles. Always inspect fasteners and components during routine servicing.

CONTENTS OF YOUR KIT

012402 Front Box Kit

Part #	Qty	Description
082404R	1	Pitman Arm
03492	1	Track Bar Bracket
02322BK	2	Bump Stop- Black
02476	1	Radius Arm Brkt - DRV
02477	1	Radius Arm Brkt - PASS
01253B	1	Sway Bar Drop - DRV
01254B	1	Sway Bar Drop - PASS
143	1	1-1/8 x 7/32 x 1.6222 Sleeve
01797	2	Bolt Tab
27031	1	Fish Wire
02475	2	Brake Line Brkt
342701	1	Loctite
099000	2	Cable Tie
02470	2	Weld in Bung
02471	2	Front Sleeve
95105A169	2	1/2" Rivet Nut
7	2	1.00 x .120 x 3.25 Sleeve
95105A159	5	3/8" Rivet Nut
YJTC5	2	Spacer
03494	2	Skid Plate Relocation
799	1	Rivet nut Installation Bolt Pack
694	1	Bolt Pack - Track Bar Bracket
	1	18mm-2.5 x 90mm Bolt
	1	18mm-2.5 Prevailing Torque Nut
	2	3/4" SAE Washer
	2	1/2" SAE Washer
	2	1/2" - 13 Nut (non-locking)
	8	3/8"-16 x 1-1/4" Bolt
	4	3/18"-16 Serrated Edge Nut
	8	3/8" SAE Washers
	1	3/8"-16 x 1" Self-Tapping Bolt
	2	5/16"-18 x 1" Self-Taping Bolt
	2	8mm-1.25 x 45mm Bolt
	2	5/16" SAE Washer
	1	3/8"-16 x 1-1/2" Bolt
	1	3/8" Star Washer External Tooth
	1	7/16"-20 Hex High Nut
793	1	Bolt Pack - Rad Arm Drop Brackets
	2	5/8"-11 x 5" bolt - grade 8 - yellow zinc
	4	5/8" USS Washer - yellow zinc
	2	5/8"-11 Prevailing torque nut - yellow zinc
	2	3/4"-10 x 5-1/2" bolt - grade 8 - yellow zinc
	4	3/4" SAE Thru hardened washer - yellow zinc
	2	3/4"-10 Prevailing torque nut - yellow zinc
	4	1/2"-13 x 1-1/4" bolt - grade 8 - yellow zinc
	4	1/2" USS Washer - yellow zinc
422	1	Bolt Pack - Sway Bar Drop
	4	3/8"-16 x 1-1/4" bolt grade 8 yellow zinc
	4	3/8"-16 prevailing torque nut yellow zinc
	8	3/8" USS flat washer thru-hardened yellow zinc

032401 Front Spring Box Kit

Part #	Qty	Description
032401R	1	4" Lift Power Wagon Gas Coil - DRV
032402R	1	4" Lift Power Wagon Gas Coil - PASS

012256 Rear Box Kit

Part #	Qty	Description
032209R	2	Rear Coil Springs
03493	1	Rear Track Bar Bracket
02499	2	Rear Bump Stop Spacer
911112	2	Rear Sway Bar Links
145	1	1.00 x 0.120 x 2.125 Sleeve
SB58BK	4	Hourglass Bushing - Black
62147	4	.625 x .075 x 1.375 Sleeve
02880	1	Brake Line Bracket
124	4	0.875 x 0.187 x 0.500 Sleeve
695	1	Bolt Pack
	2	1/4"-20 x 3/4" Bolt
	2	1/4"-20 Prevailing Torque Nut
	4	1/4" SAE Washer
	4	10mm-1.50 x 50mm Bolt
	4	10mm Flat Washer
674	1	Bolt Pack
	1	9/16"-12 x 4" Bolt
	2	9/16" SAE Thru-hardened Washer
	1	9/16"-12 Prevailing Torque Nut
	1	3/8"-16 x 1-1/2" Bolt
	1	3/8" SAE Washer
	1	3/8"-16 Serrated Edge Flanged Nut
	1	7/16"-14 x 1-1/2" Bolt
	2	7/16" SAE Thru-hardened Washer
	1	7/16"-14 Prevailing Torque Nut
	4	10mm-1.50 x 80mm Bolt
	4	10mm Washer
	4	12mm-1.75 x 65mm Bolt
	8	7/16" USS washer
	4	12mm-1.75 Prevailing Torque Nut

INSTALLATION INSTRUCTIONS

PRE INSTALLATION NOTES:

6.4L Gas models will require exhaust modification to clear the front driveshaft. The vehicle can be driven without the front driveshaft to an exhaust shop for modification and reinstalled after modification.

SPECIAL TOOLS

- #1: Pitman arm puller
- #2: 11/16" drill (step drill highly recommended)
- #3: Welder
- #4: Socket for pitman arm nut (1-13/16" or 46 mm)

MEASURE FIRST

Measure from the center of the wheel up to the bottom edge of the wheel opening:

LF _____ RF _____

LR _____ RR _____

TRANSFER CASE INDEXING RING / CROSS MEMBER INSTALLATION

This kit will require the installation of a transmission indexing ring and replacement crossmember. 6" gas models reference the 122616 instruction sheet.

RADIUS ARM INSTALLATION INSTRUCTIONS

1. Park vehicle on clean flat and level surface. Block the rear wheels for safety.
2. Disconnect the battery / batteries, welding will be required. Do not weld on the vehicle with the batteries connected.
3. Remove the front trackbar bolt from the frame rail. Retain all hardware. (Fig 1)

FIGURE 1

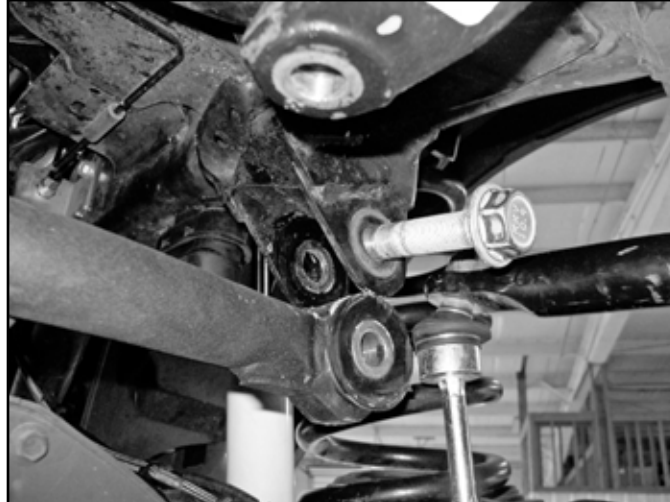

4. Raise the front of the vehicle and support the frame rails with jackstands. Do not support on the radius arms, they will be removed during the installation.

FRONT SUSPENSION DISASSEMBLY

5. Support the front axle with a hydraulic jack.
6. Remove the factory wheels, remove the retaining clips that hold the rotor on and may interfere with aftermarket wheels.
7. Break the jam nuts loose on the adjusting collar of the drag link. (Fig 2)

FIGURE 2

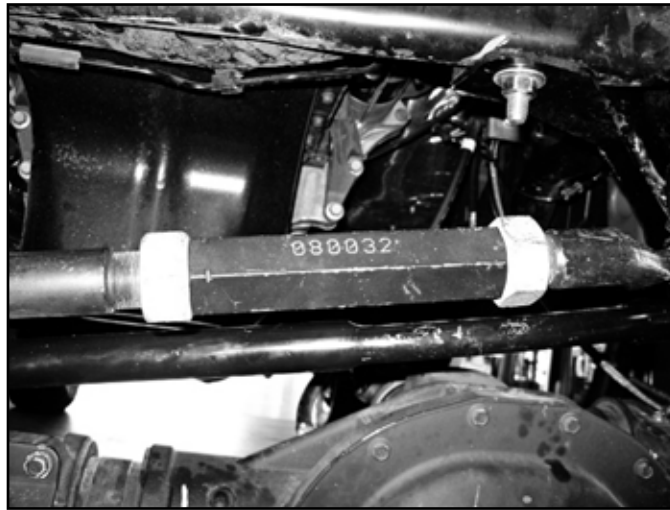

8. Disconnect the tie rod from the pitman arm, do not damage the tie rod boot. Mark the orientation of the pitman arm and remove the pitman arm from the sector shaft. (Fig 3)
9. Disconnect the wire harness from the front differential. Unclip the wire harness from the front axle.
10. Disconnect the sway bar links from the sway bar. Retain all hardware. (Fig 4)

FIGURE 3



FIGURE 4



11. Disconnect the brake line bracket from the top of the radius arm mount on the axle, retain bolt, discard bracket. (Fig 5)
12. Disconnect the factory shock from the lower shock mount. (Fig 6) Lower the front axle and remove the factory coil springs.

FIGURE 5



FIGURE 6

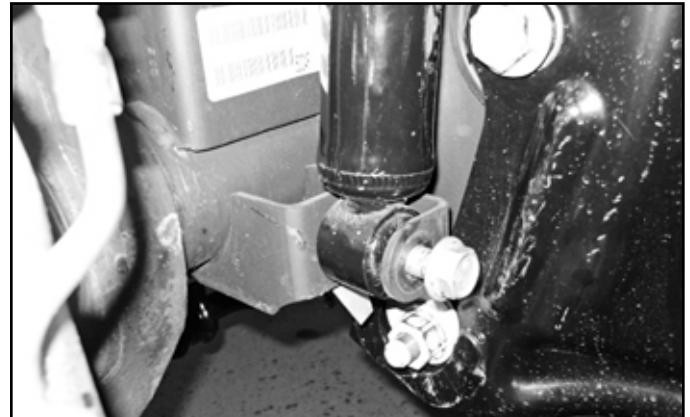

13. Raise the front axle and reattach factory shocks with factory bolt. It is not necessary to put the nut tab back on. The shocks will be there to keep the axle secure. Keep a jack under the axle for extra support.
14. Mark the cam at the axle. Remove the passenger's side radius arm. Retain all hardware. It will be necessary to remove the shock bolt and move the shock out of the way to get the upper hardware out. Reinsert the lower shock bolt when the arm is removed.

RADIUS ARM DROP BRACKET INSTALLATION

15. On the passenger's side only. Measure and mark as shown (Fig 7) This small amount of material will need to be removed for clearance to the new radius arm drop bracket. The inside edge of the cut will be flush with the transmission crossmember. The outside edge will be flush with the radius arm mounting plate. Measure up 1/4" and remove this material for clearance.
16. Place the radius arm drop bracket up to the frame rail. Insert 3/4" bolt to locate the bracket. Mark the center of the slot on the bottom of the frame rail, mark the center of the top, rear hole on the side of the frame rail. (Fig 8)

FIGURE 7

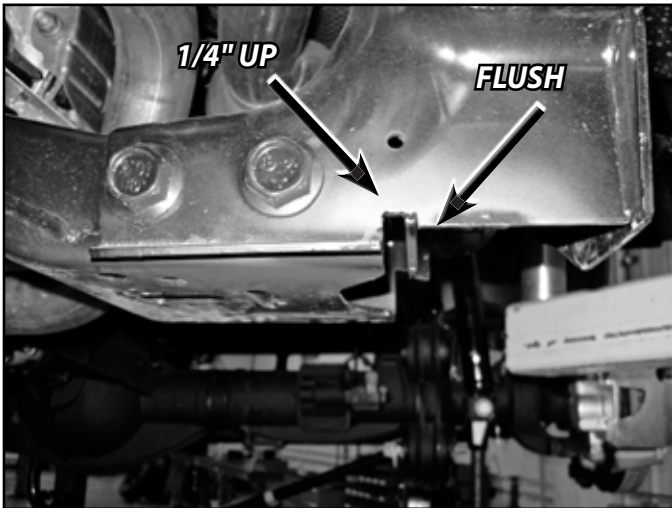
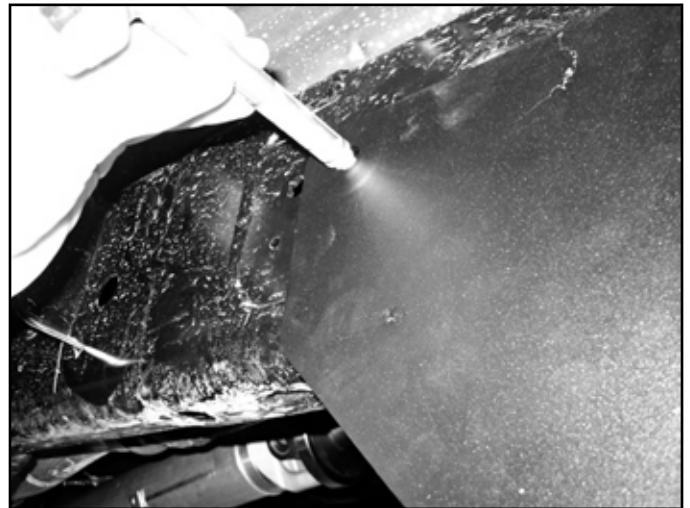

FIGURE 8



17. Remove the bracket and drill the 2 centers to 11/16". Prep the area on the side of the frame rail for welding. Place the weld in bung into the hole and weld the bung into place. (Fig 9)

FIGURE 9



18. Insert the rivet nut into the bottom of the frame rail. Use the hardware (#799) to set the rivet nut into place as shown (Fig 10). See the end of the instruction sheet for detailed rivet nut installation instructions.

FIGURE 10



19. Place the machined sleeve into the existing frame rail hole. Reinstall the bracket with hardware (#793) and sleeve as shown (Fig 11A, 11B, 11C)

FIGURE 11A



FIGURE 11B

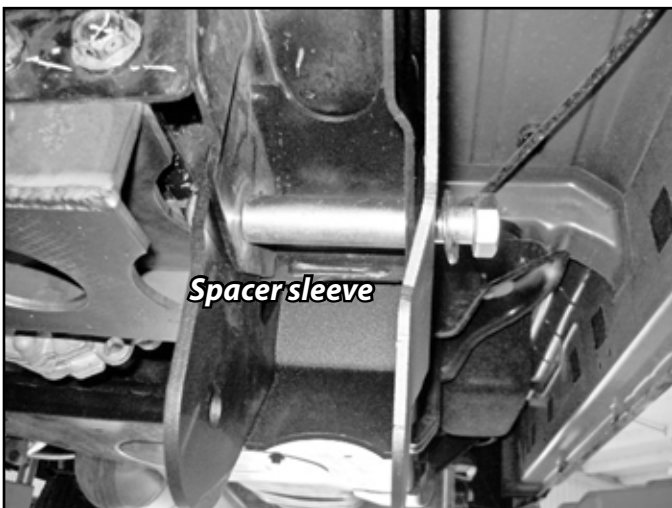
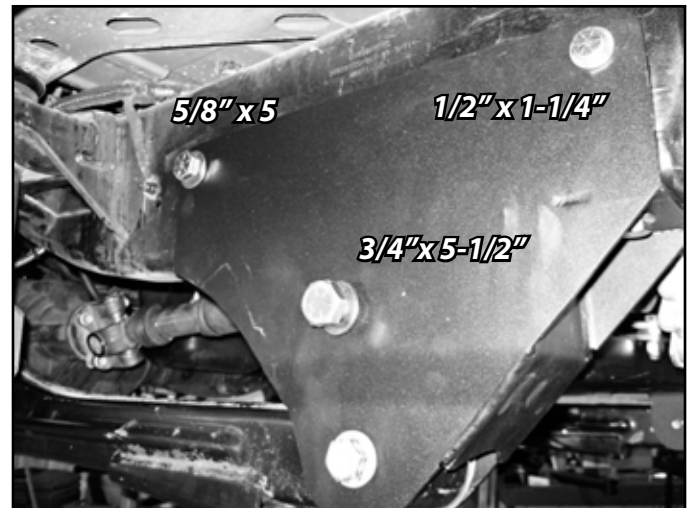

FIGURE 11C



20. With a jack still under the axle, disconnect the radius arm from the driver's side frame bracket. Reinstall the passenger's side radius arm with factory hardware. Rotate the cam to the marked position. Leave hardware slightly loose.

21. Repeat bracket installation procedure on the driver's side.



Tip *The trimming for clearance on the frame bracket is not required on the driver's side.*

22. Reinstall the driver's side radius arm with factory hardware. Rotate the cam to the position marked at the beginning of the installation. Snug all hardware, do not tighten at this time.

BUMP STOP INSTALLATION

23. Remove the factory bump stops, it is easiest to hit them from side with a hammer to pop them out. (Fig 12)

FIGURE 12



24. Grease new replacement bump stops and raise axle to press the bump stops into position. These will be a tight fit. It is easiest to lift the axle with a jack to compress the bump stops into position. (Fig 13)

FIGURE 13



TRACK BAR BRACKET INSTALLATION

25. Install the trackbar bracket with the provided 18mm hardware in Bolt Pack 694 and 143 sleeve (1-1/8" OD x 1.62") through the factory track bar hole.
26. Clearance the two factory slotted holes on the bottom of the frame crossmember where the trackbar bracket meets to 9/16".
27. Fish the bolt tabs through the frame rail with the included bolt wire. Apply Loctite to the bolt tab threads and attach to the trackbar bracket with 1/2" washer and regular nut. (Fig 14A, 14B)

FIGURE 14A

FIGURE 14B



28. Tighten 1/2" trackbar hardware to 65 ft-lbs. Tighten 18mm bolt to 150 ft-lbs.

INDEXING RING INSTALLATION

29. Remove the factory transfer case skid plate (Fig. 15), along with the 3 bars on the passenger side of the vehicle (Fig 16). Retain hardware.

FIGURE 15

FIGURE 16



30. Remove the rear crossmember for drive shaft clearance. The rear crossmember will be relocated forward. Remove the fuel tank skid plate hardware attached to the rear crossmember (Fig 17). Retain hardware for the skid plate. The hardware attaching the rear crossmember to the frame can be discarded.

FIGURE 17



INDEXING RING INSTALLATION

- 31. Refer to indexing ring kit instructions at this time for indexing ring installation.
- 32. Forward of the rear crossmember mounting location is a set of hex holes on the driver's side. Drill out the hex holes to $17/32$ " and install a $3/8$ " rivet-nut in each hole. (Fig 18A & 18B) See the end of the instruction sheet for detailed rivet nut installation instructions.

Note: Figure 18A shows the factory rear crossmember holes on the right. The new hexholes shown on the left are approximately 9 inches in front of the factory mount location

FIGURE 18A

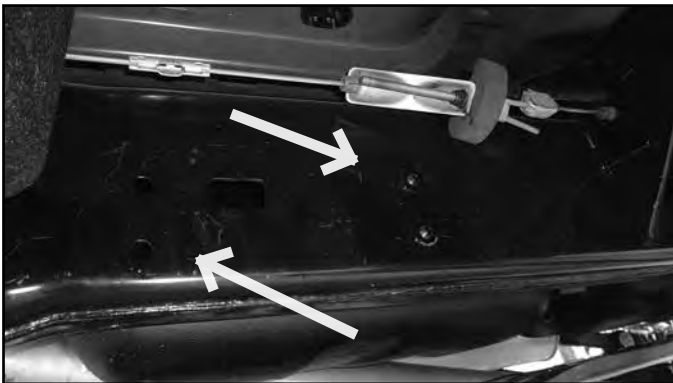

FIGURE 18B



- 33. The passenger's side will have a single hex hole. Measure vertically up $1-7/8$ " from the center of the hex and drill this hole and the hex hole out to $17/32$ " (Fig 19). Install a $3/8$ " rivet nut in each hole.

Note: The single hex hole in Figure 19 is approximately 9 inches in front of the factory mount location. The factory mount was 2 bolts side by side, while the new mounting will be two vertical bolts (See Figure 20 for reference)

FIGURE 19



34. Install the rear crossmember into the four newly installed rivet-nuts with the (4) 3/8" x 1-1/4" bolt and (4) 3/8" SAE Washers provided in bolt pack 694. (Fig 20)



Tip The rear crossmember must be mounted as low as possible in the slots for driveshaft clearance.

FIGURE 20



35. Attach the fuel tank skid plate to the two outer factory holes in the rear crossmember with the provided spacer plates (03494) and factory hardware with Loctite. This is shown on the left in Figure 21.
36. Drill a 21/64" hole through the center of the skid plate and rear crossmember. Install the provided 3/8" self tapping bolt through the drilled hole, tightening the skid plate to the rear crossmember. This is shown by the right arrow in Figure 21.

FIGURE 21

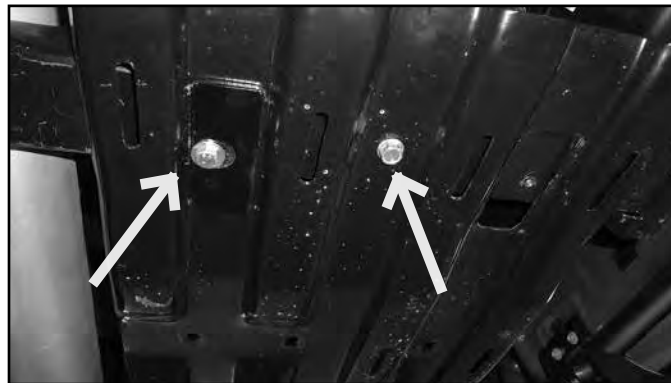

37. Install the transfer case skid plate with the provided 3/4" spacer (YJTC5) and 8mm hardware, 5/16" SAE washer, and Loctite into the factory holes in the middle crossmember. (Fig 22A) Attach the front of the transfer case skid plate to the new crossmember with the provided (2) 3/8" x 1-1/4" bolts, (2) 3/8" SAE Washer, and (2) 3/8" serrated edge nuts. (Fig 22B)

FIGURE 22A



FIGURE 22B



38. Cut the rear long section off of the two skid plate bars. (Fig 23)



Tip Do not cut the hole off the shorter section. There should be 2 holes in the final part.

FIGURE 23



39. Using the cut shorter skid plate bars from the previous step, using a bench top vise, bend the ends so that they offset (approximately 1") to account for the new front dropped crossmember and factory middle crossmember. (Fig 24A) Install the two skid plate bars into the outer two factory holes on the middle crossmember with factory hardware and the new front crossmember with the provided (2) 3/8" x 1-1/4" bolts, (2) 3/8" SAE Washer, and (2) 3/8" serrated edge nuts. (Fig 24B). The middle skid plate bar location will not be used.

FIGURE 24A



FIGURE 24B



COIL SPRING INSTALLATION

40. Support front axle and remove the factory shocks. Retain the lower hardware, discard shocks and upper hardware.
41. Lower the axle and install the new coils with factory isolator. The Driver's side coil will install with the isolator tab in the factory hole. The Passenger's side isolator will need to be rotated just over 45 degrees. Cut and place the template up to the factory mount, mark hole center and drill to 1/2". ONLY on the passenger's side. (Fig 25A & 25B)

FIGURE 25A



FIGURE 25B



42. Install the upper isolator on the passenger's side as shown in the new hole. (Fig 26A & 26B). Install the springs with the factor isolator. The springs are side specific and marked on each spring with DRV and PASS.

FIGURE 26A - INCORRECT

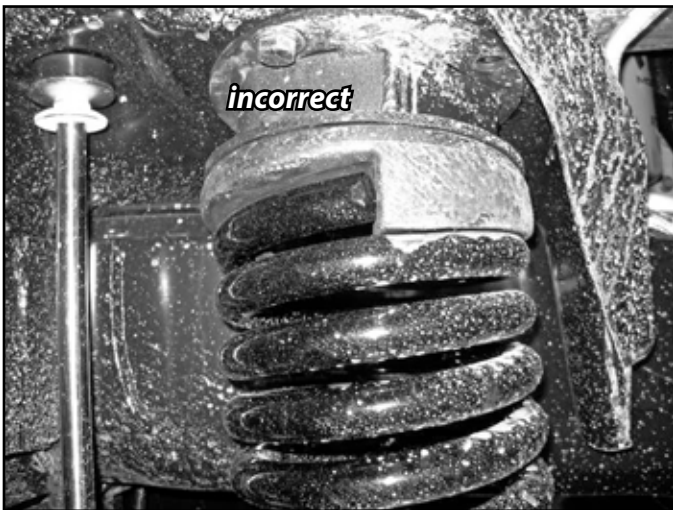
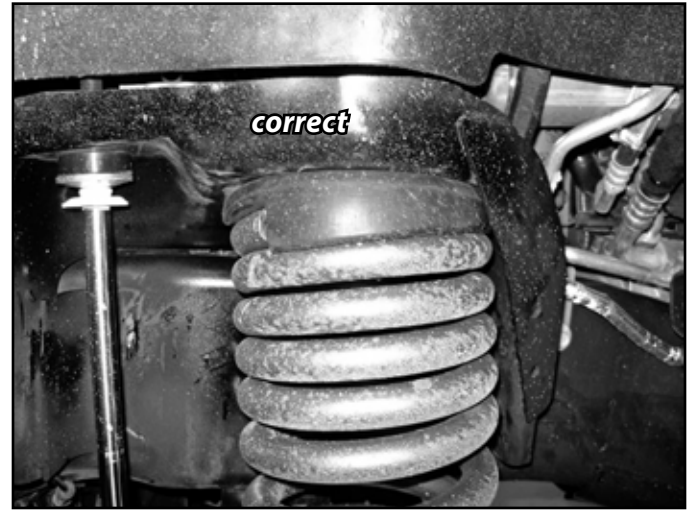

FIGURE 26B - CORRECT



43. Grease and install bushings and sleeves into the shocks. Install new shocks with cup washers, bushings, and 1/2" nut at the top mount. Tighten the nut until the bushings begin to swell.
44. Attach the lower shock with factory hardware. Tighten hardware to 65 ft-lbs.
45. Disassemble the drag link. Trim the tab from the tie rod end flush with the end of the threads (Fig 27A, 26B). Trim the end of the tab on the drag link to 1-1/4" long (Fig 28).

FIGURE 27A

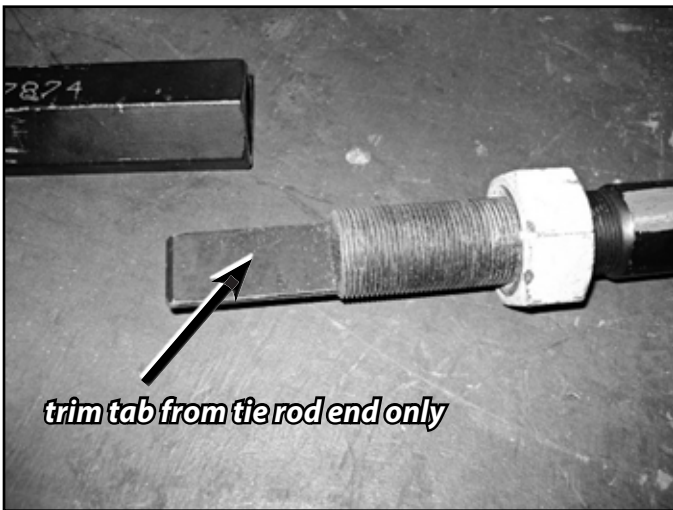
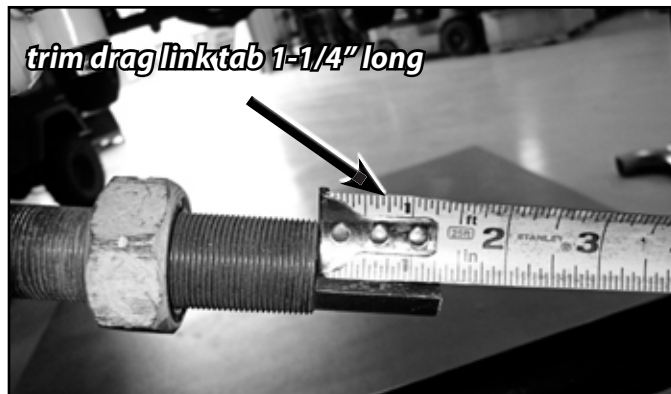

FIGURE 27B



FIGURE 28



46. Reassemble the drag link, adjust so that there is approximately 3/4"~7/8" of thread exposed past the jam nuts and that the tie rod end faces up. (Fig 29)

FIGURE 29



47. Install new pitman arm, use alignment mark made earlier. Liberally apply Loctite to the factory nut and install with lock washer and tighten nut to 225 ft-lbs.
48. Attach drag link to pitman arm with factory nut. Tighten to 65 ft-lbs. (Fig 30)

FIGURE 30

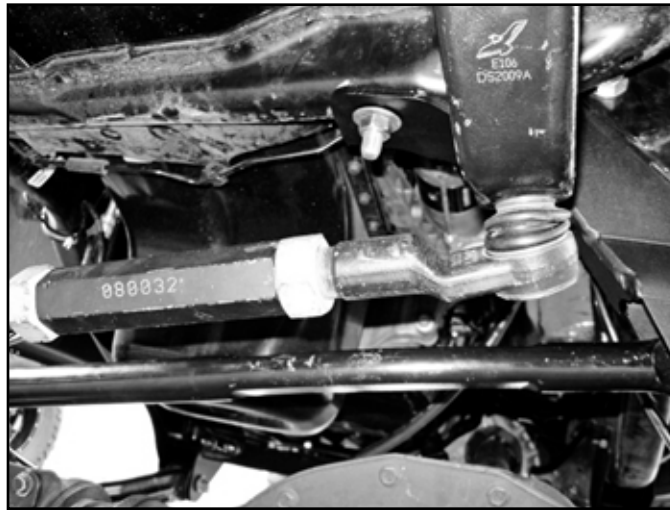

49. Attach brake line relocation brackets to the top side of the axle with the factory bolt and 5/16" self threading bolt into the original locating tab hole. The brake lines will need to have the fittings loosened so they can be rotated and pointed up. Attach the brake line to the bracket with retaining clip. The brackets will need to be offset in towards the 'inside' of the vehicle to give more clearance to the larger body of the shock. It will be necessary to slightly reform the hard line. (Fig 31)

FIGURE 31



50. Working on one side at a time, install the sway bar drop brackets with factory hardware at the frame. The flat side of the bracket will face 'out' and the brackets will offset the sway bar slightly forward. Attach sway bar to drop brackets with 3/8" hardware, tighten all hardware to 35 ft-lbs. (Bolt Pack #422) (Fig 32A, 32B) . Check the slack for the sway bar disconnect wiring.

FIGURE 32A



FIGURE 32B



51. Reinstall sway bar links to the sway bar. Tighten to factory specification.
52. Reinstall the wire harness to the locking front differential. Additional slack may be needed at full droop. The wire harness can be run underneath the crossmember or removed from some wire clips for adequate slack.
53. Install wheels and tighten lug nuts to factory specifications. Lower the vehicle to the ground.
54. Tighten radius arm hardware to 150 ft-lbs. Adjust radius arm Cam so the bolt is as far forward as possible. (Fig 33)

FIGURE 33



55. Turn the steering wheel to get the trackbar to align with the bracket. Install the factory 18mm bolt and tighten to 150 ft-lbs. (Fig 34)



Tip *Make sure the wing on the factory nut points up and is hid behind the bracket.*

FIGURE 34



REAR INSTALLATION

56. Disconnect the rear trackbar from the axle, retain all hardware. (Fig 35)

 **Tip** You may need to detach the vent hose clip from the track bar bracket to prevent the nut tab from puncturing the vent hose.

FIGURE 35



57. Raise rear of vehicle and support frame rails with jack stands.
58. Remove the rear wheels.
59. Support the rear axle with a hydraulic jack.
60. Disconnect the rear brake lines from the back of the rear differential housing. Retain hardware.
61. Disconnect the rear sway bar links from the frame and sway bar. (Fig 36)

FIGURE 36



62. Disconnect the 4 bolts attaching the rear power hop damper to the top of the rear axle housing.

Note: The rear power hop damper is extremely stiff, it is easiest to leave the damper connected to the rear bracket.

63. Disconnect the rear shocks and lower the axle, retain hardware. On the driver's side it is easiest to access the top hardware by cutting the inner fender well as shown. This trim procedure is not required but greatly aids in removal and installation of the shock. (Fig 37A, 37B)
64. Remove the rear coil springs and upper and lower coil spring retainers.

FIGURE 37A

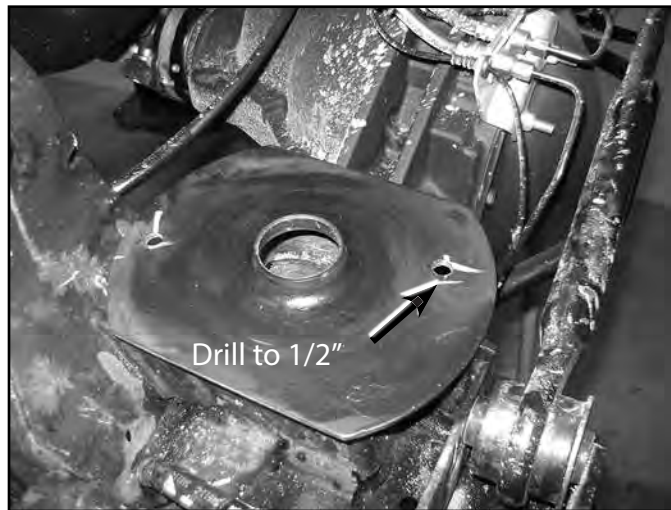

FIGURE 37B



65. Locate the holes in the rear lower coil mount. Clearance the rear most hole on the driver's side to 1/2" to accept larger hardware. (Fig. 38)

FIGURE 38



66. Install the trackbar bracket to the axle, hardware is located in bolt pack 674. First loosely attach the bracket using the 7/16" hardware through coil spacer and lower coil mount. Next, place the 2-1/8" long sleeve (145) and place it inside the track bar bracket at the factory track bar bolt location using the factory track bar bolt and nut tab. Using the 3/8" x 1-1/2" bolt, washer, and flange nut attach the bracket through the bottom hole. (Fig. 39A, 39B)

Note: Figure 39 shows a coil spacer installed, in this kit a replacement rear coil spring is used. It is best to run the 7/16" bolt from the top down.

FIGURE 39A

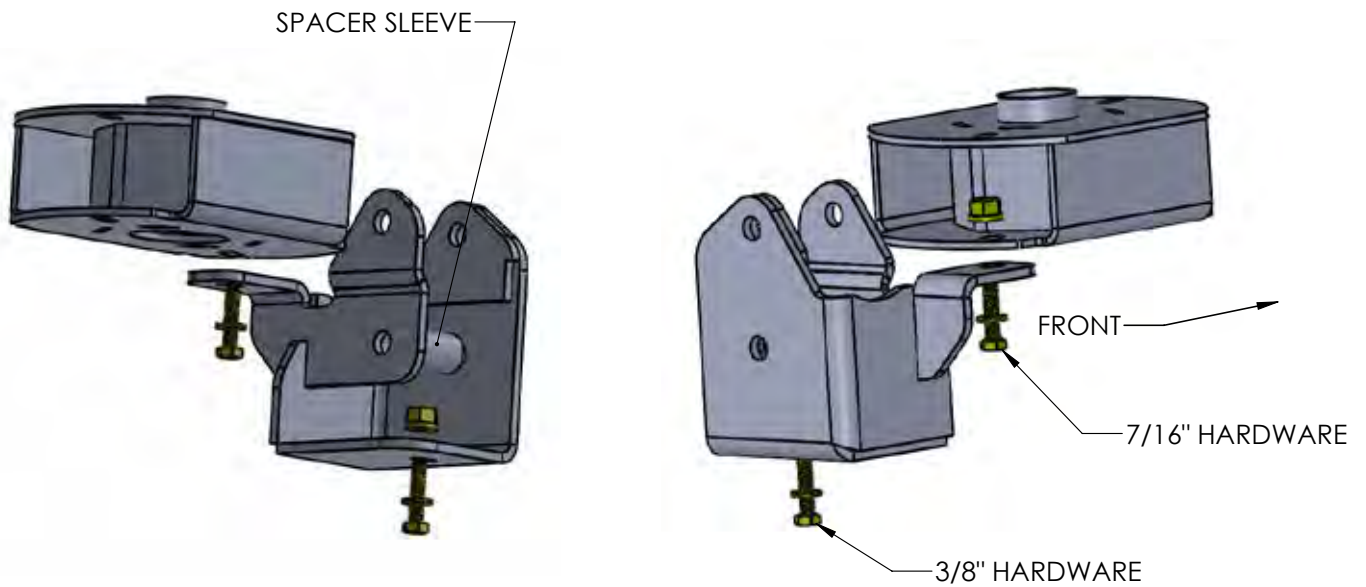
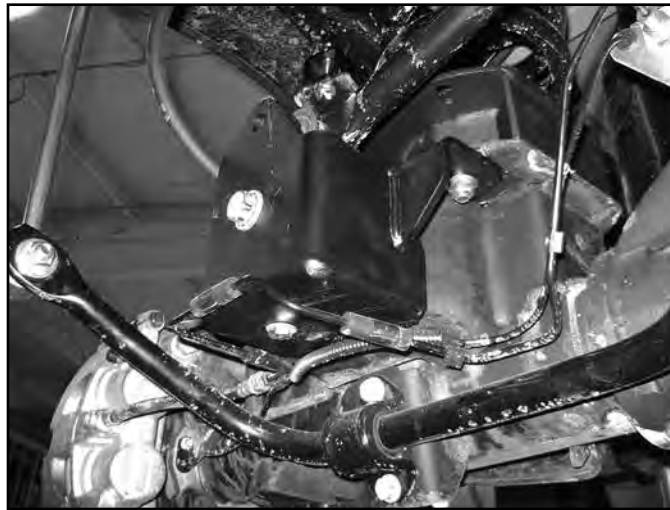

FIGURE 39B



67. Tighten trackbar bracket hardware as follows: 14mm factory hardware 95 ft-lbs, 7/16" hardware 45 ft-lbs, 3/8" hardware 35 ft-lbs,
68. Install new coil springs with OEM isolators. New coil springs will require the transfer of the plastic wrap from the factory coils to the new coils. The plastic spring wrap will eliminate any possible noise from the progressive coils. Raise axle and ensure that the isolators are centered over the factory mounts. Orientate the coils so that the lower locating tab is at the rear of the vehicle. This will give maximum clearance to the trackbar hardware. (Fig 40)

FIGURE 40



69. The shocks will require an offset stem eliminator bracket and bolt pack 946 The eye of the shock will need to be offset to the REAR of the vehicle to give the shock body clearance to the frame rail hole. Locate the OE frame hole towards the rear of the vehicle from the original stem mounting hole. Enlarge this hole using a 3/8" drill bit to fit to the tab on the offset bracket. Verify shock clearance to the frame opening, in may be necessary to slightly enlarge the opening due to variances in trucks, however this is highly unlikely. (Fig. 41)



Tip *This is shown in Figure 41.*

FIGURE 41



70. Attach the rear power hop damper to the top of the rear axle housing with the 4 provided spacer sleeves (124) and 10mm bolts and washers from bolt pack 695 (Fig. 42).

FIGURE 42



71. Install the rear brake line extension to the rear differential housing with the factory hardware. Attach the brake lines to the rear brake line extension with the provided 1/4" hardware in bolt pack 695 (Fig. 43).

FIGURE 43



72. Grease bushings and sleeves and install into sway bar links. Install sway bar links with new 12mm hardware. (BP 674). Tighten to 45 ft-lbs. (Fig 44)

FIGURE 44

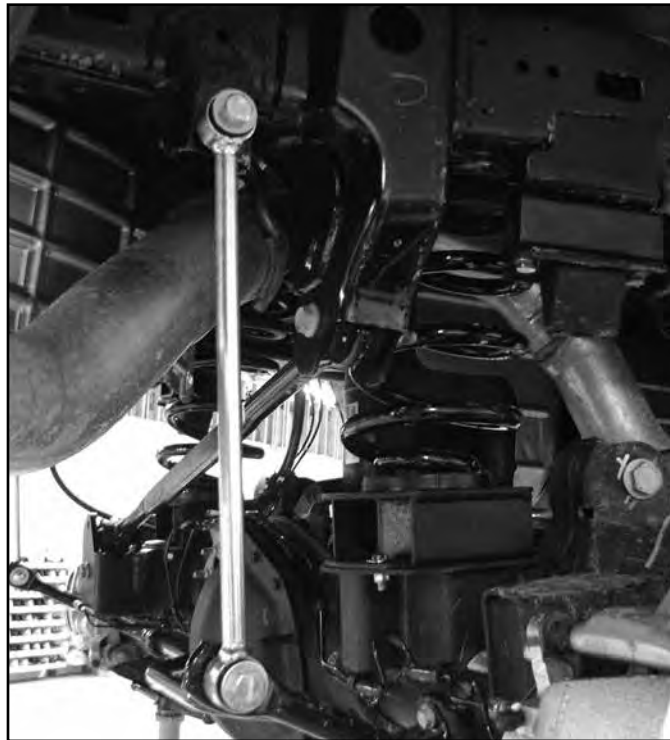

73. Remove the factory bump stops and spacer. Install bump stop drop brackets with new 10mm hardware (BP 674). Install so the small holes are to the inside. Tighten to 35 ft-lbs. (Fig 45A, 45B)

 **Tip** *The spacer used in Power Wagon models is not reused.*

FIGURE 45A



FIGURE 45B



74. Reinstall wheels, if installing aftermarket wheels it is recommended to remove all of the rotor retaining clips to allow the wheel to sit flush against the rotor. Tighten to factory specifications.
75. Lower vehicle to the ground.
76. Attach trackbar to the new bracket with 9/16" x 4" hardware (BP 674). It may be necessary to have an assistant push on one side of the truck slightly to get the holes aligned. Tighten to 95 ft-lbs.
77. Recheck all hardware for proper torque, check again after 500 miles.

POST-INSTALLATION

1. Adjust the steering wheel to center with the collar on the drag link. Securely lock off the jam nuts once the wheel is straight. Do not drive the vehicle with the steering wheel off-center or adverse traction control problems may arise.
2. Recheck all hardware, check again at 500 miles, and again at regularly scheduled maintenance intervals. Check brake lines and ABS wires for proper clearance through steering sweep, use zip ties on the ABS wires if necessary. An alignment must now be performed.

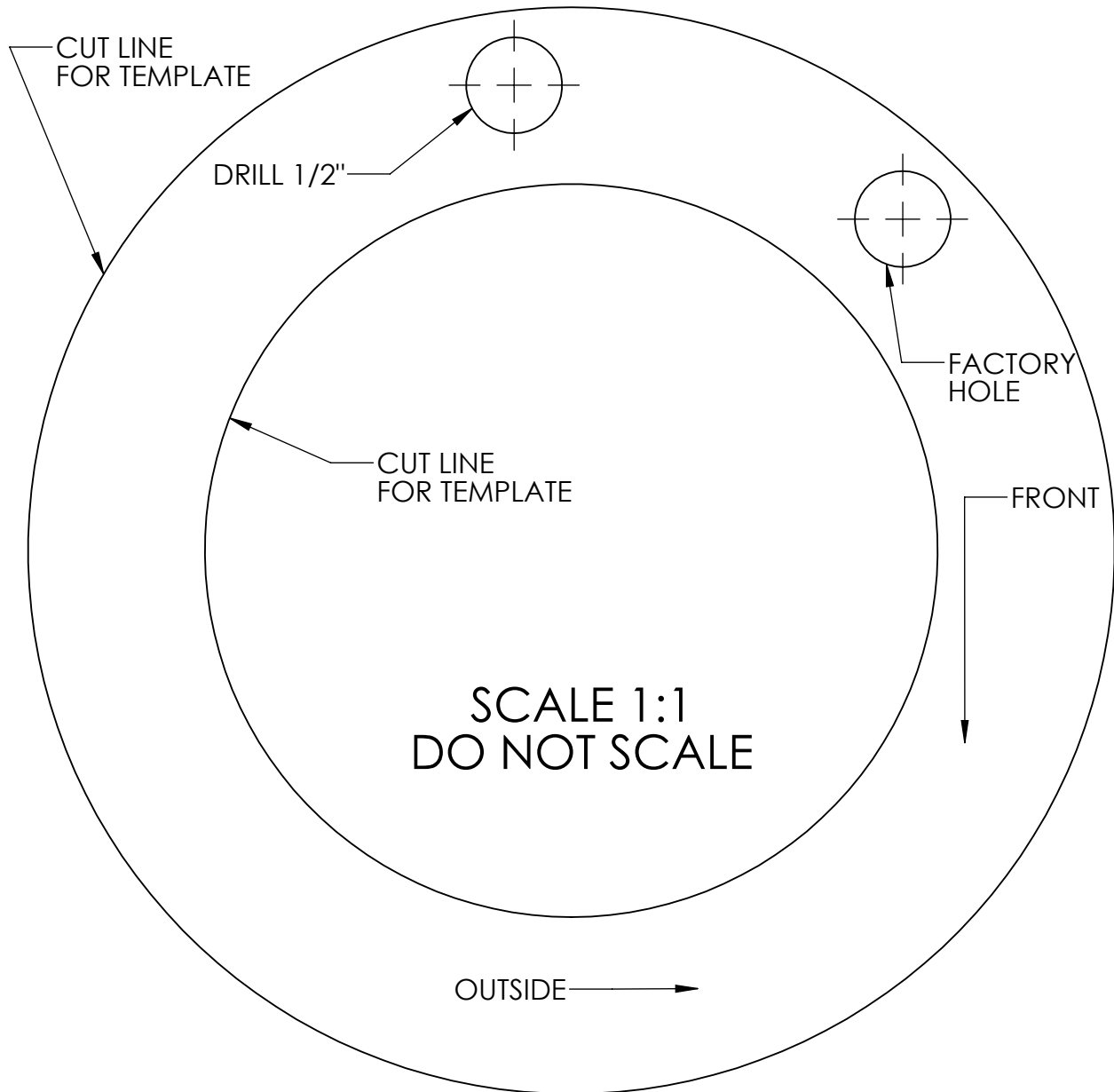

RIVET NUT INSTALLATION INSTRUCTIONS

RIVET NUT SIZING

1. Verify the correct size rivet nut for the application based on the thickness of material where the rivet nut is to be installed using the following chart.

Part Number	Thread Size	Body Length (in)	Material Thickness (in)		Drill Size (in)
			Min.	Max.	
95105A159	3/8-16	.690	.027	.150	17/32
95105A168	3/8-16	.805	.150	.312	17/32
95105A169	1/2-13	1.150	.063	.200	11/16
95105A170	1/2-13	1.300	.200	.350	11/16

HOLE PREPARATION

2. Drill hole to appropriate size for rivet nut installation. 1/2" Rivnuts require an 11/16" hole and 3/8" Rivnuts require a 17/32" drill. It is critical that this hole is drilled to the correct size. Remove any burrs that could keep the rivet nut from seating flat against either side of the hole surface.



Tip If the correct drill size is not available, it is possible to drill the hole to an available smaller size and slowly grind it out to until the rivet nut fits tight.

RIVET NUT INSTALLATION TOOL ASSEMBLY

3. For a 3/8" rivet nut, place the provided 3/8" SAE flat washer on the 3/8" x 1-1/2" bolt, followed by 7/16" hex nut and then a 3/8" serrated washer. (Fig. 1) Thread this tool assembly into the rivet nut.
4. For a 1/2" rivet nut, place the provided 1/2" SAE washer on a 1/2" x 2" bolt followed by a 9/16" high nut and 1/2" serrated edge lock washer. Thread this tool assembly into the rivet nut as shown. (Fig 1)

FIGURE 1- 1/2" RIVET NUT SHOWN

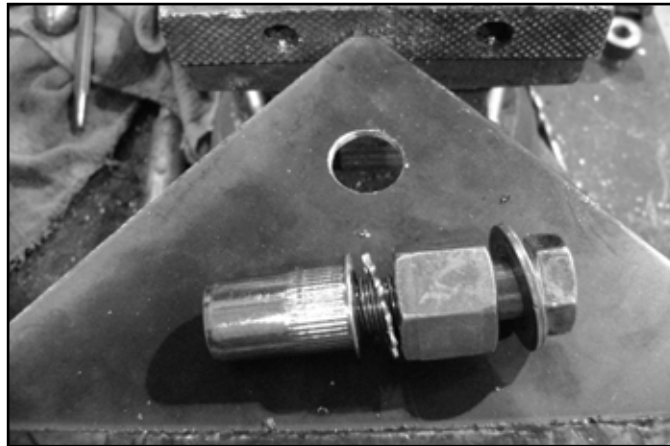

RIVET NUT INSTALLATION

5. Place the installation tool with the rivet nut threaded on the end into the appropriately sized hole.
6. For a 3/8" rivet nut, hold the nut closest to the rivet nut still with an 5/8" wrench and tighten the 3/8" bolt with a 9/16" wrench to set the rivet nut. Be sure to hold the rivet nut flush to the surface and square to the hole as it is tightened. (Fig. 2)



Tip If available, an impact gun is recommended for tightening the bolt to ensure the rivet nut remains square to the hole and to ease holding the nut from spinning.

7. For a 1/2" rivet nut, hold the nut closest to the rivet nut still with an 7/8" wrench and tighten the 1/2" bolt with a 3/4" wrench to set the rivet nut. Be sure to hold the rivet nut flush to the surface and square to the hole as it is tightened. (Fig. 2)

FIGURE 2 - 1/2" RIVET NUT SHOWN



TORQUE SPECIFICATIONS

8. 3/8" rivet nuts will approach 40 ft. lbs for maximum grip strength. Do not exceed 45 ft-lbs when setting the rivet nut.
9. 1/2" rivet nuts will approach 90 ft lbs for maximum grip strength. Do not exceed 100 ft-lbs when setting the rivet nut.



Tip

Note: If using the recommended impact gun, use caution to not exceed the recommended torque specifications.

RIVET NUT TOOL REMOVAL

10. Once the center bolt is tightened, remain holding the nut from spinning with the wrench and loosen the center bolt to remove the installation tool.



Caution

It is very important to hold the nut as the bolt is loosened because the grip of the star washer will try to spin the rivet nut and ruin the installation.

11. Verify proper installation by checking for consistent rivet nut deformation to see the threads are square and centered to the rivet nut. (Fig. 3)

FIGURE 3

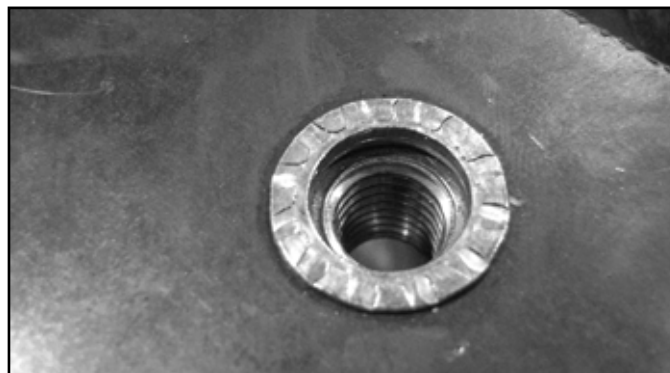



WE WANT TO SEE YOUR RIDE!

Grab photos of your BDS-equipped truck in action and send them in for a chance to be featured. Send it in to our Bad Ass Rides customer gallery at bds-suspension.com/bar and post them on the BDS Fan Page on Facebook at facebook.com/BDSSuspensions. Don't forget about your BDS swag! BDS offers t-shirts, hoodies, decals and more available on the BDS website or through your local BDS distributor.

TIME TO HAVE SOME FUN

Thank you for choosing BDS Suspension.

For questions, technical support and warranty issues relating to this BDS Suspension product, please contact your distributor/installer before contacting BDS Suspension directly.