

INSTALLATION GUIDE

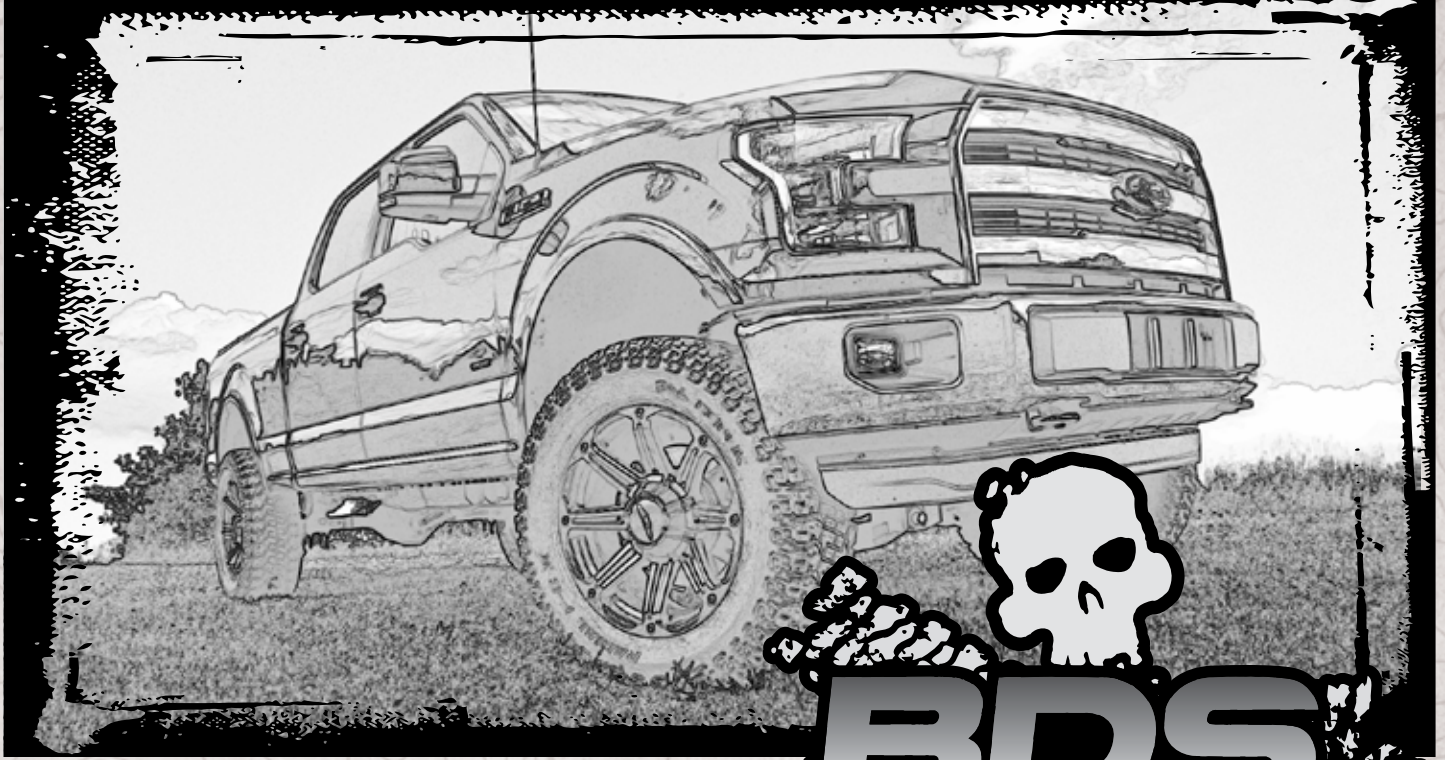

Part#: 023650



HARDCORE LIMITED LIFETIME WARRANTY

4" & 6" Suspension System

Ford F150 4WD | 2017-19

Rev. 062819

491 W. Garfield Ave., Coldwater, MI 49036 • Phone: 517-279-2135
E-mail: tech-bds@ridefox.com

Read And Understand All Instructions And Warnings Prior To Installation Of System And Operation Of Vehicle.

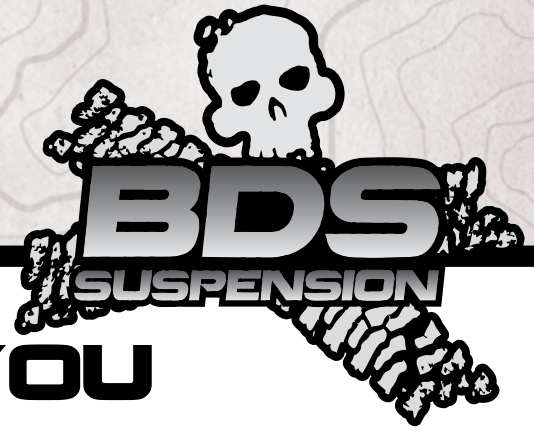

THANK YOU

Your truck is about to be fitted with the best suspension system on the market today. That means you will be driving the baddest looking truck in the neighborhood, and you'll have the warranty to ensure that it stays that way for years to come. Thank you for choosing BDS Suspension!

BEFORE YOU START

BDS Suspension Co. recommends this system be installed by a professional technician. In addition to these instructions, professional knowledge of disassembly/ reassembly procedures and post installation checks must be known.

FOR YOUR SAFETY

Certain BDS Suspension products are intended to improve off-road performance. Modifying your vehicle for off-road use may result in the vehicle handling differently than a factory equipped vehicle. Extreme care must be used to prevent loss of control or vehicle rollover. Failure to drive your modified vehicle safely may result in serious injury or death. BDS Suspension Co. does not recommend the combined use of suspension lifts, body lifts, or other lifting devices. You should never operate your modified vehicle under the influence of alcohol or drugs. Always drive your modified vehicle at reduced speeds to ensure your ability to control your vehicle under all driving conditions. Always wear your seat belt.

BEFORE INSTALLATION

- Special literature required: OE Service Manual for model/year of vehicle. Refer to manual for proper disassembly/reassembly procedures of OE and related components.
- Adhere to recommendations when replacement fasteners, retainers and keepers are called out in the OE manual.
- Larger rim and tire combinations may increase leverage on suspension, steering, and related components. When selecting combinations larger than OE, consider the additional stress you could be inducing on the OE and related components.
- Post suspension system vehicles may experience drive line vibrations. Angles may require tuning, slider on shaft may require replacement, shafts may need to be lengthened or trued, and U-joints may need to be replaced.
- Secure and properly block vehicle prior to installation of BDS Suspension components. Always wear safety glasses when using power tools.
- If installation is to be performed without a hoist, BDS Suspension Co. recommends rear alterations first.
- Due to payload options and initial ride height variances, the amount of lift is a base figure. Final ride height dimensions may vary in accordance to original vehicle attitude. Always measure the attitude prior to beginning installation.

BEFORE YOU DRIVE

Check all fasteners for proper torque. Check to ensure for adequate clearance between all rotating, mobile, fixed, and heated members. Verify clearance between exhaust and brake lines, fuel lines, fuel tank, floor boards and wiring harness. Check steering gear for clearance. Test and inspect brake system.



Visit 560plus.com for more information.

TRACTION CONTROL

In an effort to reduce the risk of rollover crashes the National Highway Traffic Safety Administration (NHTSA) established the Federal Motor Vehicle Safety Standard (FMVSS) No. 126 requiring all new passenger vehicles under 10,000 lbs GVWR include an electronic stability control (ESC) system as standard equipment. Effective August 2012 this law requires aftermarket products to be compliant with these same standards.



TIRES AND WHEELS

FITMENT GUIDE

- 6" Lift:**
37x12.50 on 18x9 with 5" backspacing*
37x12.50 on 20x9 with 5.5" backspacing
- 4" Lift:**
35x12.50 on 18x9 with 5" backspacing*
35x12.50 on 20x9 with 5.5" backspacing

*See troubleshooting notes



Perform steering sweep to ensure front brake hoses have adequate slack and do not contact any rotating, mobile or heated members. Inspect rear brake hoses at full extension for adequate slack. Failure to perform hose check/ replacement may result in component failure. Longer replacement hoses, if needed can be purchased from a local parts supplier.

Perform head light check and adjustment.

Re-torque all fasteners after 500 miles. Always inspect fasteners and components during routine servicing.

CONTENTS OF YOUR KIT

BDS023634 - Knuckle Box - Drv

Part #	Qty	Description
02805	1	Knuckle - Drv
02487	1	Ball Joint Washer

BDS023635 Knuckle Box - Pass

Part #	Qty	Description
02806	1	Knuckle - Pass
02487	1	Ball Joint Washer

BDS023404 (4" only) BDS023605 (6" only)

Part #	Qty	Description
02427	2	4in Strut Spacer (023404)
02725	2	6in Spacer
B1067	1	Bag Kit
769	1	Bolt Pack
	6	7/16"-14 nylock nut
	6	3/8" USS flat washer
629	1	Bolt Pack
	6	10mm-1.50 prevailing torque nut
	6	3/8" USS flat washer

BDS013539 (6" only)

Part #	Qty	Description
02085	2	5" Rear Block
02086	2	Lower Spring Plate
02087B	2	Upper Spring Plate
963181212QB	4	9/16 x 3-1/8 x 12-1/2 Square U-bolt
01716	1	Brake Line Bracket
120400FCP	2	1/2 x 4 Pin w/Nut
W96S-B	8	9/16 SAE Flat Washer
N96FH-B	8	9/16 Fine High Nut
465	1	Bolt Pack
	2	1/2"-20 x 3-1/2" bolt - grade 8 - flat SHCS - black oxide
	2	1/2"-20 nut - black oxide - (non locking / regular nut)
	1	1/4"-20 prevailing torque nut - clear zinc
	1	1/4" USS washer - clear zinc

BDS013439 (4" only)

Part #	Qty	Description
02429	1	4" Offset Rear Block - Drv
02430	1	4" Offset Rear Block - Pass
963181212QB	4	9/16 x 3-1/8 x 12-1/2 Square U-bolt
01716	1	Radiator Relocation Bracket
120400FCP	2	1/2 x 4 Pin w/Nut
W96S-B	8	9/16 SAE Flat Washer
N96FH-B	8	9/16 Fine High Nut
704	1	Bolt Pack
	2	1/4"-20 prevailing torque nut - clear zinc
	2	1/4" USS washer - clear zinc

BDS023650 Front Box Kit 1 of 2

Part #	Qty	Description
02078	1	Driveshaft Spacer
02779	1	Front Crossmember
03675	1	Rear Crossmember
03453	1	Diff Support Bracket - Drv
02001	8	F150 Eccentric Cam
02002	4	F150 Eccentric Bolt
N18MPT	4	M18-2.5 prevailing torque nut
01602	2	Strap w/stud
925	1	Bolt Pack - Driveshaft Spacer
	6	10mm x 100mm Socket Head Cap Screw

BDS023651 Front Box Kit 2 of 2

Part #	Qty	Description
03452	1	Diff Drop Bracket - Drv
03454	1	Diff Drop Bracket - Pass
03455	1	Diff Support Bracket - Pass
02803	1	Diff Skid Plate
02781	2	Sway Bar Drop
400408-10	1	5/16" x 10" Hose
772	1	Bolt Pack - Differential Drop
	3	9/16"-12 x 4" bolt
	5	9/16"-12 x 1-1/4" bolt
	16	9/16" flat washer
	8	9/16"-12 Prevailing torque nut
	4	7/16"-14 x 1-1/4" bolt
	8	7/16" SAE flat washer
	4	7/16"-14 prevailing torque nut
773	1	Bolt Pack
	2	18mm-2.50 x 150mm bolt
	4	3/4" SAE washer
	2	18mm-2.50 prevailing torque nut
	2	1/4"-20 prevailing torque nut
	4	1/4" USS flat washer
	2	6mm-1.00 x 18mm bolt
	4	1/2"-13 x 1-1/4" button head bolt
	4	1/2" SAE washer
	4	3/8"-16 x 1-1/4" bolt
	8	3/8" SAE flat washer
	4	3/8"-16 prevailing torque nut

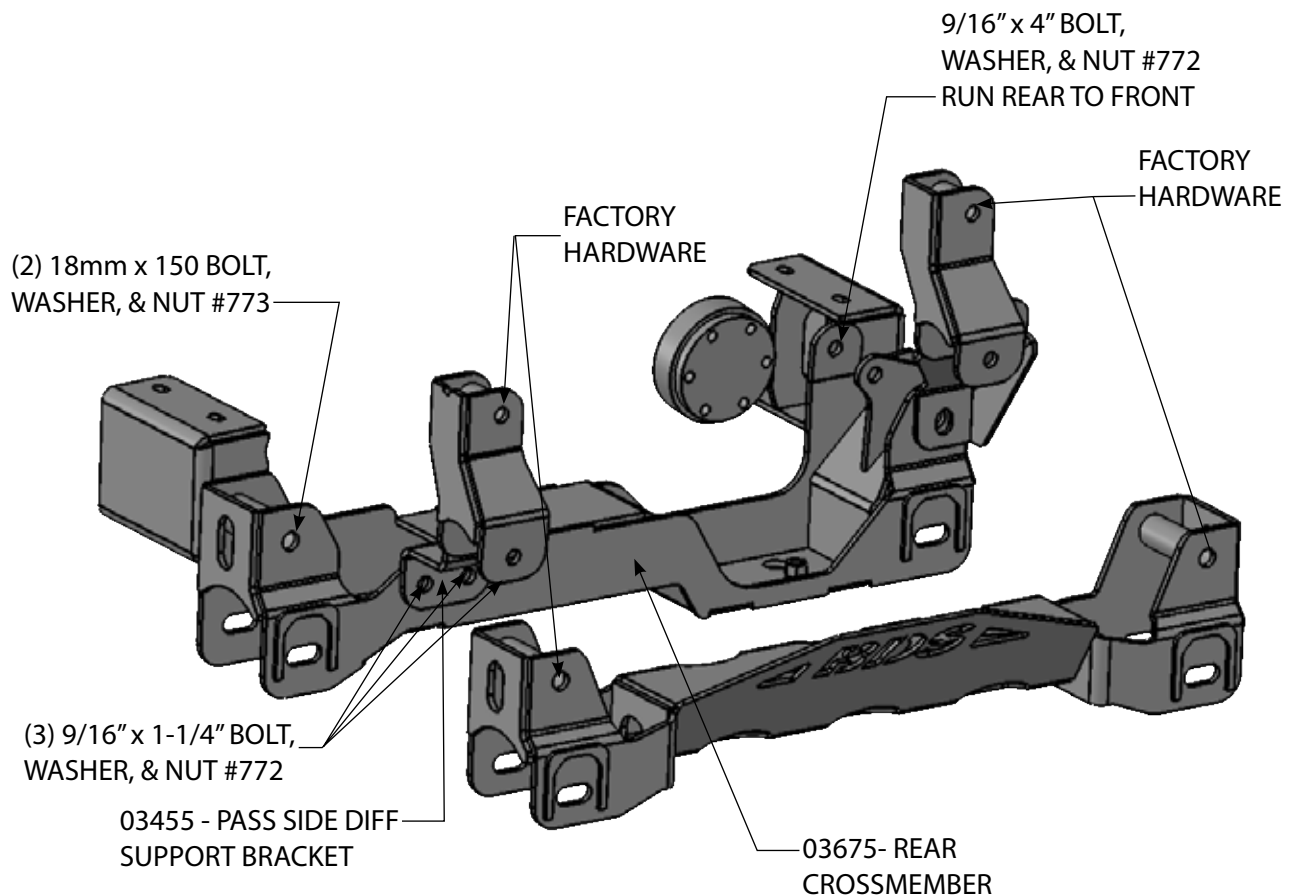
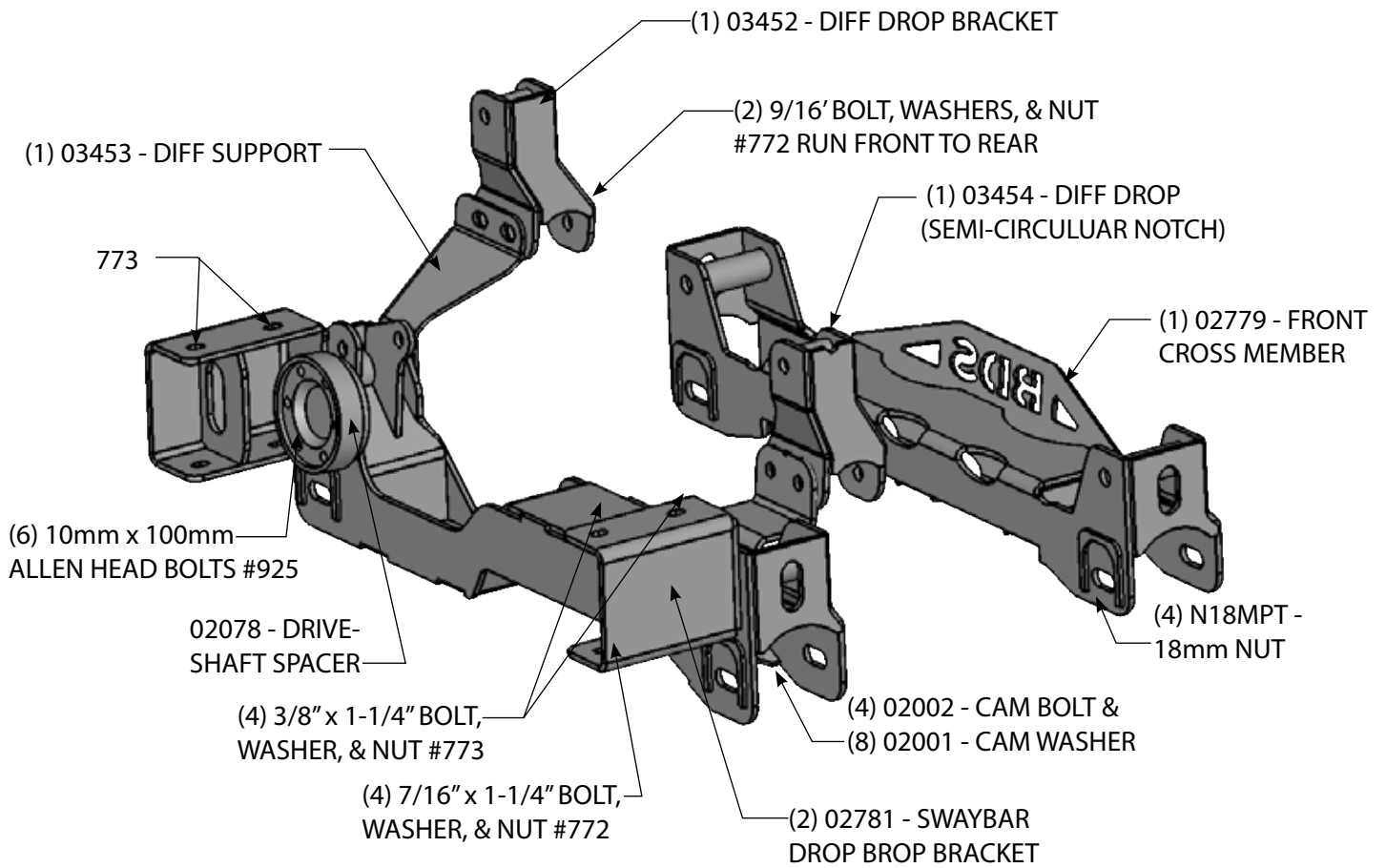

TROUBLESHOOTING INFORMATION FOR YOUR VEHICLE

1. 18" wheels with 5-5.5" backsacing should be test fit prior to mounting the tire to ensure proper clearance to the steering knuckle/tie rod. 5.5" backsacing is highly recommended for tire to frame crash bar clearance.
2. 18" or larger diameter wheels required. Stock 17" and 18" wheels cannot be re-installed. Stock 20" wheels can be used with up to a 305/60R20 tire.
3. Models with 2-piece rear driveshaft WILL require carrier bearing shim kit 122405 (not included w/ kit)
4. Block kits replace factory 1-1/4" block. Stock block will not be reinstalled.
5. Crash bars may require modification based on wheel and tire choice. It is the end users responsibility to ensure modifications are non-detrimental to vehicle safety.

INSTALLATION INSTRUCTIONS

FRONT INSTALLATION

1. Park the vehicle on a clean, flat surface and block the rear wheels for safety.
2. Measure from the center of the wheel up to the bottom edge of the wheel opening and record below:

LF _____ RF _____

LR _____ RR _____

3. Raise the front of the vehicle and support with jack stands at each frame rail behind the lower control arms.
4. Remove the front wheels.

! Caution *EPAS (Electronic Power Assist Steering), disconnect the power steering control module connector to avoid arcing of the contacts in the internal power relay from a hammer blow or impact wrench.*

5. Remove the brake caliper anchor bracket bolts and remove the caliper from the knuckle (Fig 1). Hang the caliper out of the way. Do not let the caliper hang by the brake hoses.

SPECIAL TOOLS

Requires frame bracket modification
Reciprocating saw or equivalent

FIGURE 1



6. Remove the brake rotor and set aside.

7. Disconnect the ABS and hub vacuum lines from the retaining clips. Disconnect the brakeline bracket from the frame rail. Disconnect the ABS line from the hub assembly. (Fig 2a / b).

FIGURE 2A

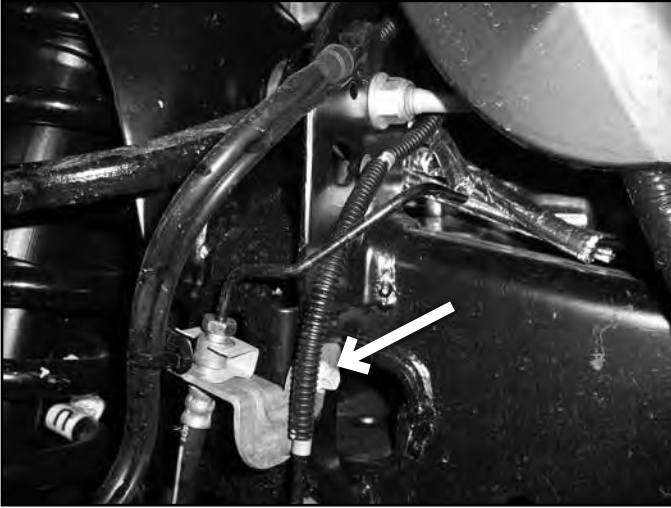

FIGURE 2B



8. Disconnect the hub vacuum line from the hub (Fig 3).
9. Disconnect the tie rod ends from the steering knuckles. Remove and retain the mounting nuts. Avoid hitting the aluminum steering knuckle, use appropriate tool to remove tie rod end from steering knuckle. Take care not to strike the tie rod end, or damage the threads. (Fig 4)

FIGURE 3

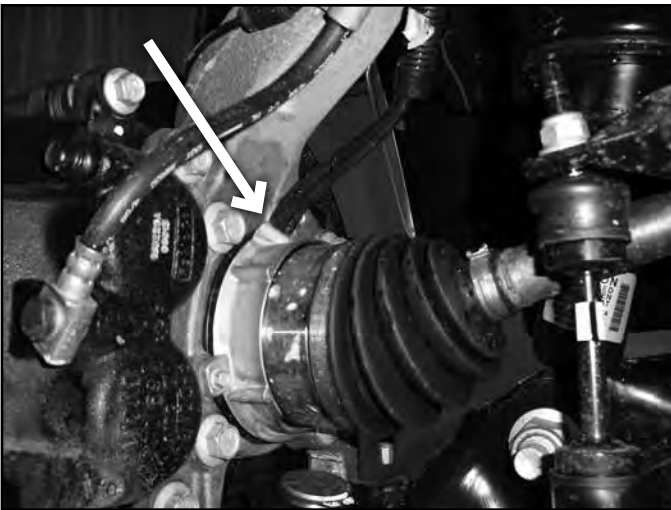

FIGURE 4



10. Disconnect the sway bar links from the sway bar (Fig 5). Retain hardware. The sway bar links do not need to be removed from the lower control arms.
11. Remove the four sway bar mounting nuts and remove the sway bar from the vehicle (Fig 6). Retain hardware

FIGURE 5

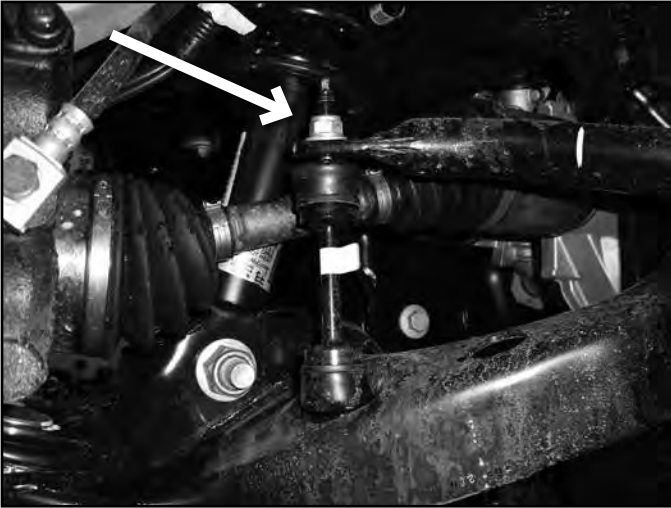

FIGURE 6



12. Carefully remove the hub dust cap to expose the axle shaft nut (Fig 7 a / b). Remove the nut. Retain the cap and nut, they will be reinstalled later.

FIGURE 7A



FIGURE 7B



13. Loosen but do not remove the three strut assembly mounting nuts at the frame (Fig 8). Do not loosen the middle strut nut.

FIGURE 8



14. Remove the upper and lower ball joint nuts, refrain from hitting the aluminum steering knuckle, use appropriate tool to separate ball joints, avoid damaging the threads.
15. Remove the upper ball joint and the strut-to-lower control arm hardware. Swing the knuckle/lower control arm down to remove the CV shaft from the hub. Retain ball joint nut and strut bolt.
16. Remove the lower ball joint nut and remove the knuckle from the vehicle. Retain hardware.
17. Remove the lower control arm mounting bolts and remove the lower control arm from the vehicle. Retain hardware.
18. Mark the struts to distinguish between driver's and passenger's.
19. Remove the three strut assembly mounting nuts at the frame and remove the strut assembly from the vehicle.
20. Take a wire brush and remove the material from the threads of the four bolts that attach the OE rear crossmember. Spray threads with lubricant and remove the bolts and crossmember from the vehicle. Discard the crossmember and hardware. (Fig 10)
21. Remove the driveshaft mounting bolts and disconnect the driveshaft from the differential (Fig 11). Allow the driveshaft to rest out of the way.

FIGURE 10



FIGURE 11



22. Remove the passengers side CV only. Strike the shaft with a hammer to dislodge it from the splines. This will make handling the differential much easier. (Fig 12)

FIGURE 12



23. Support the front differential with an appropriate jack. Loosen all of the hardware and slide the differential all the way to the passenger's side. Orientate the joint at the steering rack so there is the most possible clearance to remove the front driver's side bolt. Remove this bolt first. Disconnect the differential breather hose from the differential housing. Remove the rear driver's side and one passenger's side differential mounting bolts (Fig 13a/ 13b) and remove the differential from the vehicle.

FIGURE 13A



FIGURE 13B



24. The driver's side rear lower control arm frame pocket must be modified to provide clearance for the differential in its relocated position. On the front side measure from the inside edge of the slot 3/4" (Fig 14a / b). Make a vertical cut line at the mark.

FIGURE 14A

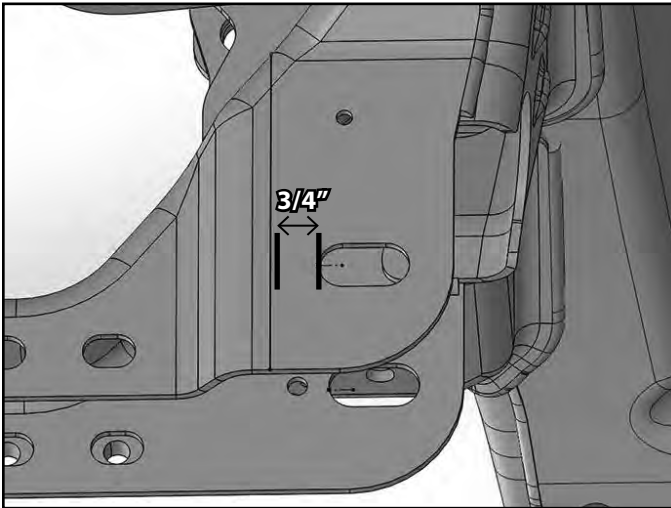

FIGURE 14B



25. On the back side measure from the inside edge of the slot 1-3/4" and make and mark a vertical cut. Measure 1-3/8" in from the angled top surface and mark (Fig 15).
26. Connect the front cut line straight to the back face. This will require trimming minor trimming on the factory differential mount tab. (Fig 16a/ b)

FIGURE 15

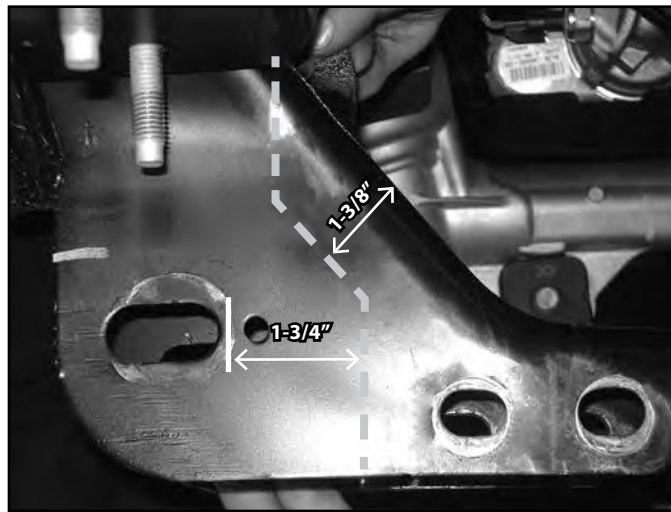

FIGURE 16A

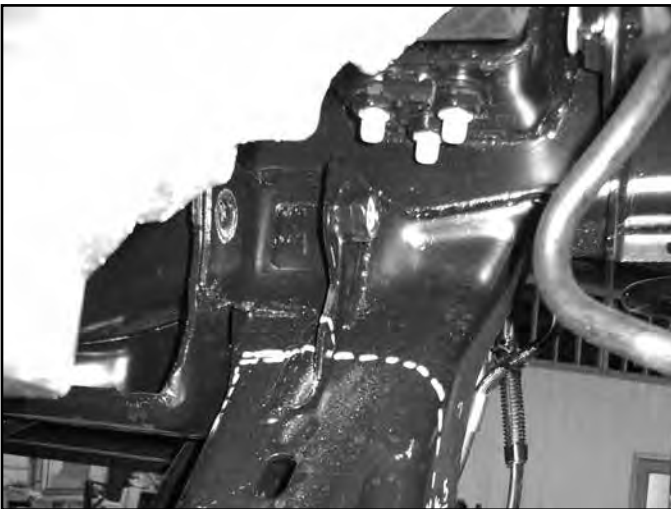

FIGURE 16B



27. Attach the differential relocation brackets (03452-Drv, 03454-Pass) to the differential with 9/16" hardware, do not tighten at this time. The passenger bracket has a circular notch cut on the top of it. Run the hardware from front to rear. Raise the differential with the brackets attached into the vehicle by aligning the differential mounts in the two front drop brackets attach to the frame with OE hardware. (Fig 18)

FIGURE 18



28. Install the new rear crossmember (02780) in the rear lower control arm frame pockets. Attach the rear crossmember with the sway bar drop brackets (02781) with new 18mm bolts and washers. Run bolts from rear to front (Fig 22a). Leave hardware loose. Ensure the cutout made in Figure 15 is adequate to clear the differential mounting bolt. (Fig 19a). Do not tighten hardware at this time.
29. Fasten the differential to the rear crossmember (Fig 19b) with a 9/16" bolt, washers, and nut (BP #772). Run the bolt from rear to front. Leave hardware loose.

FIGURE 19A

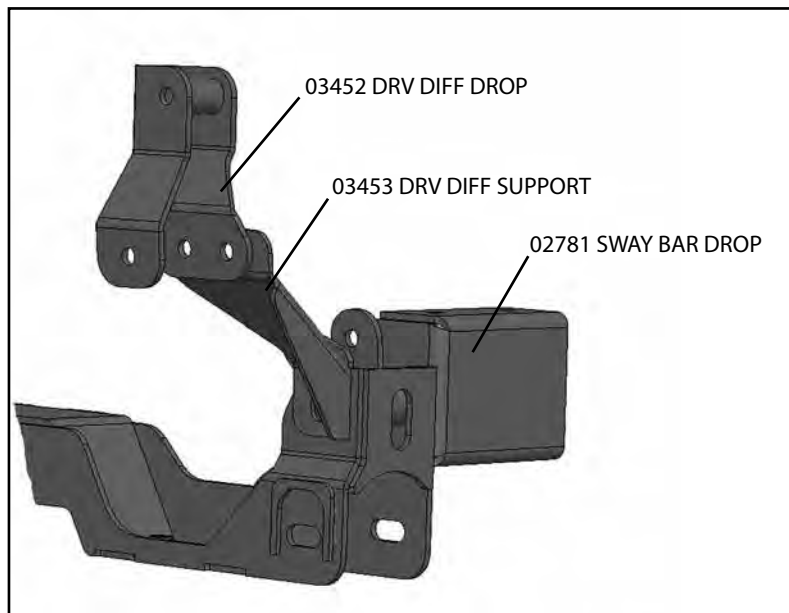

FIGURE 19B



30. Fasten the support bracket to the rear of diff drop bracket. Fasten with the driver's side rear crossmember hardware. Attach the hardware at the differential bracket from the front to rear. Leave all hardware loose at this time. (Fig 20a).

FIGURE 20A



31. Install the offset differential support bracket to the backside of the passenger's side differential bracket using the hardware that was just installed and 9/16" x 1-1/4" hardware to the BDS crossmember. Leave hardware loose. (Fig 20b)

FIGURE 20B



32. Torque all of the differential mounting hardware to 95 ft-lbs (10 total). Attach the differential breather tube. Remove the differential breather elbow from the plastic line and replace it with the provided hose and attach it to the differential.
33. Install the front crossmember in the front lower control arm pockets and fasten with the OE lower control arm hardware. Leave hardware loose.
34. Install the lower control arms in the new crossmembers and fasten with the provided 18mm cam bolts, cam washers and 18mm nuts. Run the front bolts from front to rear and leave loose. Run the rear bolts from rear to front. The main body of the cam will be 'up' in the cam slot.
35. Install the provided differential skid plate to the front and rear crossmembers with $\frac{1}{2}$ " x 1-1/4" button head bolts and $\frac{1}{2}$ " SAE washers (BP #773) into the weld nuts in the crossmembers (Fig 21). Leave hardware loose.

FIGURE 21



36. Attach the sway bar drop brackets with new $\frac{3}{8}$ " x 1-1/4" bolts, washers and nuts. Run hardware from bottom - up, snug but do not tighten at this time.



Tip Use a ratchet extension through the lower slots to access the hardware (Fig 22a/ b)

FIGURE 22A



FIGURE 22B



37. With the lower control arms installed torque the four crossmember mounting bolts to 222 ft-lbs. Ensure that the front crossmember is centered in the vehicle. Torque the differential skid plate bolts to 65 ft-lbs. Tighten sway bar drop hardware to 35 ft-lbs.
38. Reinstall the passengers side CV.

FOX COIL-OVERS REFERENCE 123611 BRACKET KIT INSTRUCTION SHEET

39. (6" kit only models) The same strut spacer is used on both sides. Place the 02725 strut spacer on each strut and attach with new 10mm nuts (#629 - located in strut box kit BDS023605). Tighten to 40 ft-lbs.
40. (4" kit only models) The same strut spacer is used on both sides. Place the 02427 strut spacer on each strut and attach with new 10mm nuts and washers (#629 - located in strut box kit BDS023404). Tighten to 40 ft-lbs.
41. Install the strut and spacer assembly into the vehicle. Attach to upper mount with new 7/16" nuts and washers (bolt pack #769). Leave hardware loose at this time. (Fig 23). Skip ahead to step 49.

FIGURE 23



4" AND 6" - ALL KITS

42. Remove the four hub bolts from the knuckle and remove the hub from the knuckle (Fig 24). Inspect mounting surface of the hub assembly and clean any dirt or corrosion off as necessary.

FIGURE 24



43. Install the hub into the corresponding new BDS knuckle (drv- 02065, pass- 02067) and fasten with the OE bolts. The ABS wire will be located at the 'top' of the hub. Use Loctite on the bolt threads and torque to 148 ft-lbs.
44. Remove the three 6mm bolts mounting the vacuum hub assembly to the inside of the OE knuckle (Fig 25). Transfer the vacuum assembly over to the new knuckle. Make sure the vacuum port is pointing towards the top. Attach with the OE bolts, tighten bolts securely (about 5-7 ft-lbs).

FIGURE 25

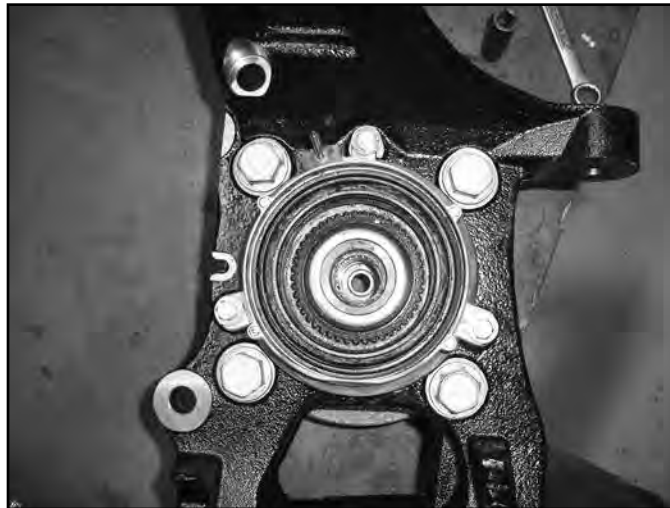

45. Install the dust shield with the factory 6mm bolts, tighten bolts securely (about 5-7 ft-lbs).
46. Install the new knuckle assembly on the lower control arm ball joint and loosely fasten with the original nut with new large machined washer (02487). Install the CV shaft in the hub, swing the whole assembly up and attach the lower control arm to the strut with the original hardware (Fox coil-overs use included hardware). Leave all hardware loose.
47. Attach the upper control arm to the knuckle with the original nut. The lower ball joint will get the large machined washer (Fig 26) (02487) included in the knuckle box kits, make sure the washer is centered before torquing lower ball joint nut. Torque the upper ball joint to 85 ft-lbs and the lower ball joint to 111 ft-lbs. (Fig 27)
48. Torque the upper strut nuts to 35 ft-lbs. The lower bolt will be tightened later with the weight of the vehicle on the suspension.
49. Fasten the CV shaft to the hub with the original nut. Make sure the splines are engaged properly in the vacuum actuated section of the hub. The hub should have a very minor amount of rotational play with the CV shaft if installed properly, torque to 20 ft-lbs. Reinstall the dust cap.
50. Install tie rod from top-down. Torque to 111 ft-lbs.
51. Install the brake rotor and caliper to the knuckle with OE bolts. Torque to 148 ft-lbs.
52. Install the brake line relocation brackets (01602) at the frame. Attach with OE hardware to frame, attach brakeline retaining clip with 1/4" nut and washer to the relocation bracket. Tighten to 15 ft-lbs.

53. Attach the ABS line to the connector at the inner fender and the vacuum line to the hub. Route the lines similar to the factory setup down to the side of the knuckle. Attach the ABS wire with the factory 6mm bolt to the side of the knuckle. Attach the brakeline with a new 6mm x 18mm bolt with 1/4" washer to the side of the knuckle (BP# 773), the brakeline locating tab will go into the unthreaded hole. (Fig 28a/ b).

FIGURE 28A

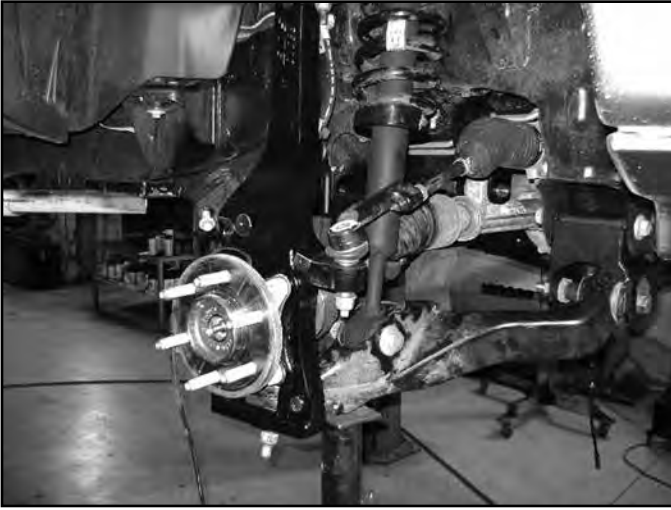

FIGURE 28B



54. Install the sway bar to the new sway bar drop brackets with 7/16" x 1-1/4" bolts, nuts and 7/16" SAE washers (BP #772). Attach the sway bar to the sway bar end links with the original hardware. Torque the 7/16" hardware to 45 ft-lbs. Torque sway bar link nut to 45 ft-lbs.
55. Install the supplied driveshaft spacer and reattach front driveshaft to differential with new hardware (BP# 925). Torque bolts to 76 ft-lbs. (Fig 29)

FIGURE 26



FIGURE 27

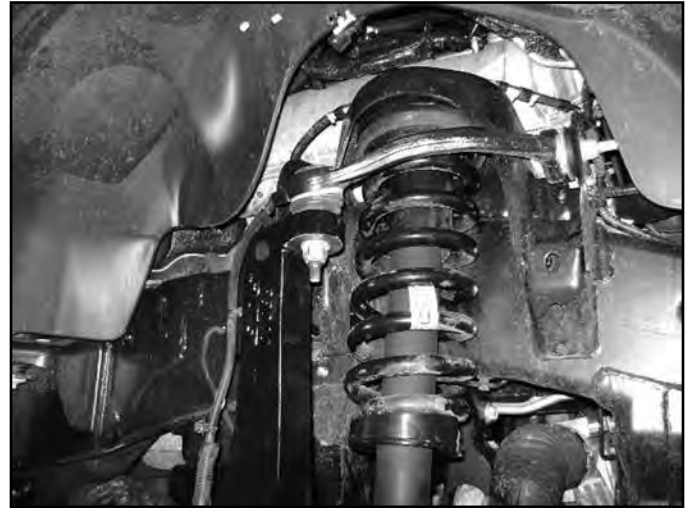

FIGURE 29



56. Install the wheels and lower the vehicle to the ground.
57. Bounce the front of the vehicle to settle the suspension. Torque the lower strut mount bolts to 80 ft-lbs. Center the lower control arm cams and torque to 250 ft-lbs. Tighten upper strut mounting hardware on replacement strut kits to 35 ft-lbs. Adjust the toe before driving it to an alignment shop.
58. Cycle steering, the crash bars that protrude from the frame may create clearance issues with the front tires. Modifications may be required for clearance.
59. Check all hardware for proper torque.

REAR INSTALLATION

60. Block the front wheels and raise the rear of the vehicle. Place jack stands under the frame rails ahead of the spring hangers.
61. Remove the wheels.
62. Disconnect the rear brake line from the frame.
63. Support the rear axle with a hydraulic jack. Remove the OE shocks. Retain mounting hardware.

Note: Perform the rear installation on one side at a time.

64. Remove the passenger's side u-bolts.
65. Lower the axle and remove the OE lift block, it will not be reused.

5" REAR BLOCK KIT, FOLLOW STEPS 66-70. 4" REAR BLOCK KITS SKIP TO STEP 71

66. Using C-clamps, clamp the leaf spring pack together on each side of the center pins. Remove the center pins and discard.
67. Place the plate on the bottom of the leaf pack and secure with new center pin in the 'forward' hole and flat head allen bolt through the 'rear' hole. Install new u-bolt retaining plate on top, it will be offset 'forward'. Tighten to 35 ft-lbs. (Fig 30, Fig 31A, B)

FIGURE 30

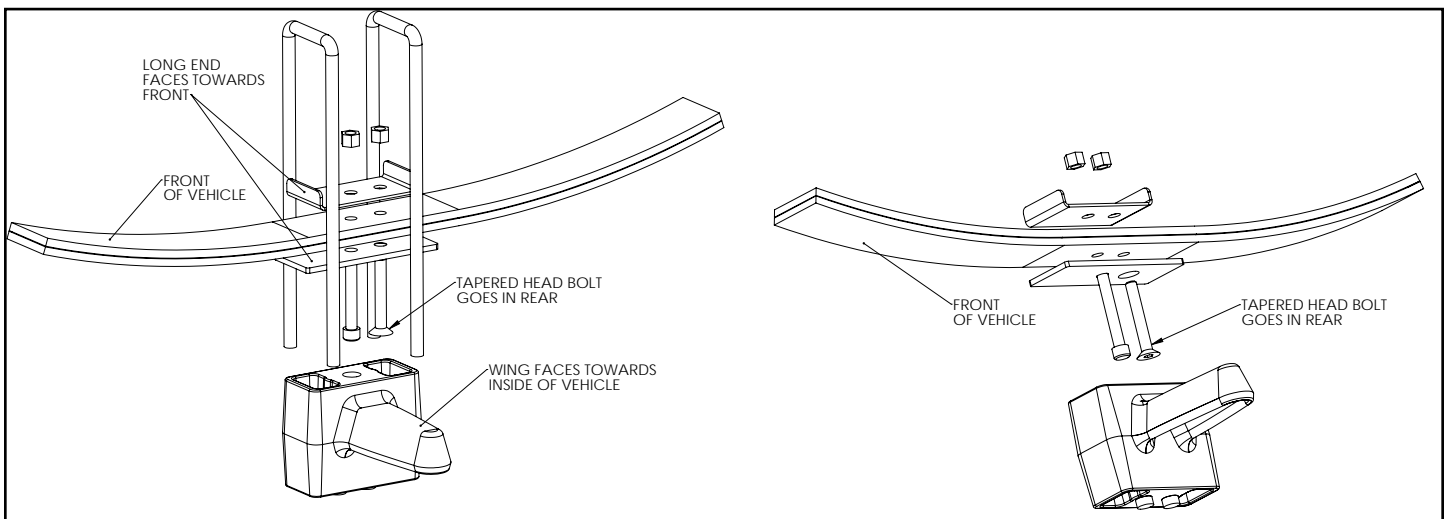
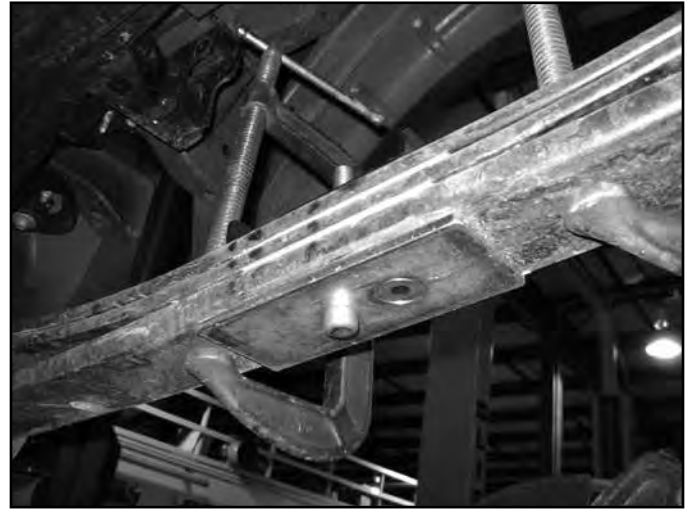

FIGURE 31A

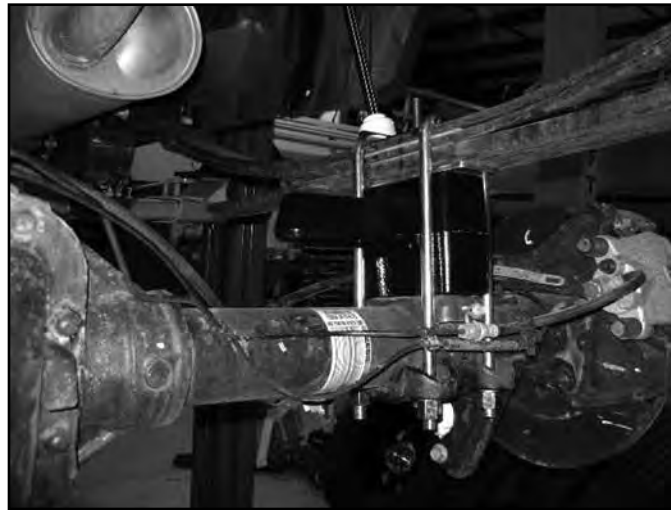

FIGURE 31B



68. Install the new provided lift block so that the bump stop wing goes toward the inside of the vehicle. The block will use the both of the lower center pin holes. The upper only uses 1 hole which will shift the axle slightly forward.
69. Raise the axle/block to the spring while aligning the center pin. Fasten the spring/block assembly with the provided u-bolts, high nuts and washers. Snug u-bolts, they will be torque with the weight of the vehicle on the springs. (Fig 32)

FIGURE 32



70. Repeat installation procedure on the driver's side of the vehicle. Skip ahead to step #76

4" REAR BLOCK KIT FOLLOW STEPS 71-72

71. Install rear block (02429 - DRV side, 02430 - Pass side). The block is designed to offset the axle forward slightly. The bump stop wing will be centered under the bump stop on the frame with the vertical gusset facing towards the front of the vehicle. Align the center pins and raise axle. (Fig 33)

FIGURE 33

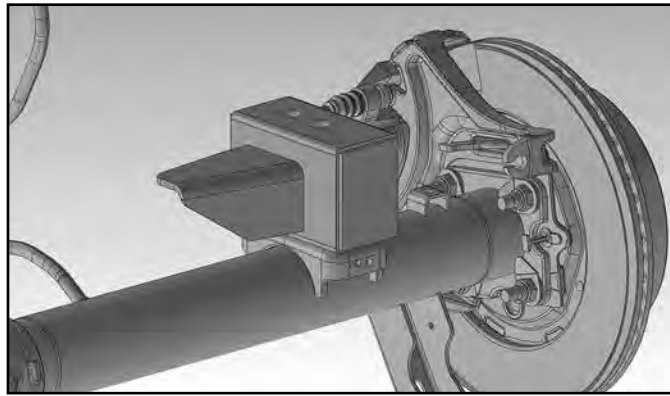

72. Attach u-bolts with the factory lower u-bolt plate. Snug u-bolts, they will be torqued to specification when the vehicle is on the ground.

ALL KITS FINAL INSTALLATION

73. Install the provided brake line relocation bracket to the driver's side frame rail with the OE brake line bracket bolt (Fig 34). Torque to 15 ft-lbs.

FIGURE 34

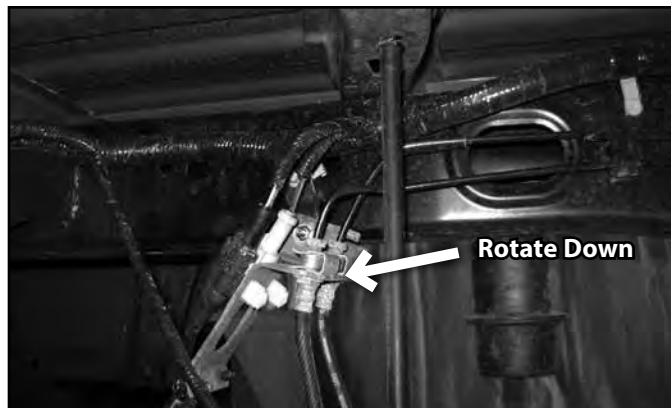

74. Attach the brake line to the relocation bracket with a 1/4" nut and 1/4" USS washer (BP #774). It may be necessary to rotate the OE brakeline clip bracket to have the lines face 'down' for adequate slack. Torque to 15 ft-lbs.
75. Install the provided new BDS shocks with the OE hardware. Torque to 60 ft-lbs.
76. Check all lines/wires for proper slack.
77. Reconnect the power steering control module connector.
78. Install the wheels and lower the vehicle to the ground.
79. Bounce the rear of the vehicle to settle the suspension.
80. Torque the u-bolts to 100-120 ft-lbs.
81. Check all hardware for proper torque
82. Check hardware after 500 miles.
83. A complete front end alignment is necessary.
84. Adjust headlights.



WE WANT TO SEE YOUR RIDE!

Grab photos of your BDS-equipped truck in action and send them in for a chance to be featured. Send it in to our Bad Ass Rides customer gallery at bds-suspension.com/bar and post them on the BDS Fan Page on Facebook at facebook.com/BDSSuspensions. Don't forget about your BDS swag! BDS offers t-shirts, hoodies, decals and more available on the BDS website or through your local BDS distributor.

TIME TO HAVE SOME FUN

Thank you for choosing BDS Suspension.

For questions, technical support and warranty issues relating to this BDS Suspension product, please contact your distributor/installer before contacting BDS Suspension directly.